



DALI Interface 64 v3 DALI Interface 64 X2 inBOX DALI 16

**KNX-DALI Interfaces for up to 64/16 ballast per channel,
16 groups and KNX security**

ZDID64X2

ZDID64V3

ZDIIBD16

Application program versions: [2.1], [2.2]

User manual edition: [2.1]_a

CONTENTS

Contents	2
Document updates.....	3
1 Introduction	4
1.1 DALI TEchnology.....	6
1.1.1 DALI system limits	6
1.1.2 Single-Master DALI-2.....	7
1.1.3 DALI bus management	7
1.1.4 Compatible ballast.....	9
1.1.5 Emergency ballasts.....	9
1.2 Dimming points	10
1.3 Power and bus failures.....	11
1.4 Priorities	12
2 Configuration.....	14
2.1 General.....	16
2.1.1 Advanced Configuration.....	18
2.2 Channel X.....	19
2.2.1 Configuration.....	19
2.2.2 ECGs.....	28
2.2.3 Dimming Points	32
3 Manual control and Display	52
3.1 Manual Control	52
3.2 Display	52
3.2.1 Channel selector.....	53
3.2.2 Main Menu	54
ANNEX I. Communication objects	66

DOCUMENT UPDATES

Version	Changes	Page(s)
[2.1]_a	Changes in the application program: <ul style="list-style-type: none">• New Multigroup functionality.• New control type Broadcast.• News Display features:<ul style="list-style-type: none">- Password.- Diagnostics.	-
[2.0]_a	New devices: <ul style="list-style-type: none">• DALI BOX Interface 64 X2 Changes in the application program: <p>Code optimisation for:</p> <ul style="list-style-type: none">• DALI BOX Interface 64 v3• inBOX DALI 16	-

1 INTRODUCTION

Zennio KNX-KNX-DALI Interface devices are controllers that allow the communication of the KNX protocol with the DALI protocol. These devices allow both configuration and individualised control and monitoring (at ballast level) through KNX communication. Zennio offers three devices for this purpose:

- **DALI BOX Interface 64 X2**
- **DALI BOX Interface 64 v3**
- **InBOX DALI 16**

This manual refers to these devices, and hereinafter are named **KNX-DALI Interface**.

The KNX-DALI controllers from Zennio are “*Single Master DALI-2*”, i.e., another application controller cannot be installed in the same DALI bus.

The main functions are:

- Output of **DALI channel**. Each channel represents an independent DALI bus.
- Integrated DALI power source.
- Ballast control by **DALI groups** (up to 16), **Individual Dimming Points** or **Broadcast** (for all ballast that are connected to DALI channel).
- Regulation of luminaires based on **DALI standard**.

In addition, other advanced functionalities are offered:

- Run and save **KNX scenes**
- **Sequences** execution.
- **Notification** of DALI channel, ballast, lamp and device **errors**.
- **Standby mode** to reduce ballast consumption by the controlling the power supply of the control points.
- **Burn-in mode** (ECGs heating), required during the beginning of lifetime of some lamps to ensure optimal lifetime.

- **Display** to show information and to allow start-up, manual control and control of scenes and burn-in on selected devices (not available on inBOX DALI 16).
- **Zennio DALI Tool; DCA** to simplify the configuration of installation on selected devices. Please refer to the compatible version in the product section at www.zennio.com.
- Execution of function tests for emergency ballasts (type DT1) according to DALI and KNX standards.
- Support of colour ballasts (type DT8) with RGB, RGBW functionality and colour temperature.
- Possibility **to choose visual perception of dimming** (logarithmic or linear) for any ballast, the **curve applied** by **ECG** for LED (DT6) and **selection curve applied** for **colour** channels RGB/W (DT8).
- **Test mode** through the specific pushbutton on **inBOX DALI 16**.
- **Heartbeat** or periodical “still-alive” notification.
- **KNX Security**. For detailed information about the functionality and configuration of KNX security, consult the specific user manual “KNX Security”, available in the product section of the Zennio web portal (www.zennio.com).

Since the general functionality is common, all three devices share this manual, however, there are some minor peculiarities. The following table shows the particular functionality for each of the **KNX-DALI Interface** devices:

	DALI BOX Interface 64 X2	DALI BOX Interface 64 v3	InBOX DALI 16
DALI Channels	2	1	1
Ballast per channel	64	64	16
DALI groups regulation points (per channel)	16	16	16
DALI individual ballast regulation points (per channel)	64	64	16
Broadcast control	✓	✓	✓
Multigroup	✓	✓	✓
Scenes (per channel)	64	64	16
Sequences (per channel)	16	16	16
Auxiliary powered	✓	✓	✗
Display	✓	✓	✗
Manual control (By button)	✗	✗	✓
Zennio DALI Tool DCA Compatibility	✓	✓	✓
KNX Security	✓	✗	✓

Table 1. Features of DALI-KNX Interfaces

1.1 DALI TECHNOLOGY

DALI (*Digital Addressable Lighting Interface*) is a communication protocol for luminaire control defined in the **IEC 62386 standard**. This standard defines the behaviour of the elements that are part of the system such as power supplies, bus topology, controllers, ballasts (also called ECGs, which stands for 'Electronic Control Gears'), sensors and other common elements in electrical lighting installations. The standard has several versions, the current version is the 2.0, known as DALI-2. Devices that follow the standard are identified with a logo that refers to the version of the standard they follow.

1.1.1 DALI SYSTEM LIMITS

The maximum elements foreseen in a DALI system are the following:

- Maximum number of ECGs in the bus: 64 (only 16 for **inBOX DALI 16**).
- Maximum number of groups: 16.
- Maximum distance of the bus: 300 m.

1.1.2 SINGLE-MASTER DALI-2

DALI communication is usually initiated by a controller by sending commands and queries to the rest of the system elements. **KNX-DALI Interface** is a controller that DALI-2 define as Single Master, that is, the interface must be the only one sending commands. The other elements shall only send their statuses, either because of a change or in response to a query.

1.1.3 DALI BUS MANAGEMENT

DALI standard foresees some commands to make the configuration and control the bus elements. **KNX-DALI Interface** uses some of these commands to configure and control the facility.

- **Command addressing:** Each command can be sent in a different way:
 - Individual: The command is sent to a specific element on the bus.
 - Group: The command is sent to the elements belonging to a group.
 - Broadcast: The command is sent to all the elements on the bus.
 - Unaddressed broadcast: The command is sent to all the elements on the bus that does not have an address.

- **Reset:** Default parameter values of the ballasts can be established by means of the Reset command. To reestablish the address of an ECG, the address 255 must be assigned. This process can be done using the “New Initialization” button on the DCA (or the “New Initialization” menu on the Display, in case of being available). During the process, after the Reset and address reestablishing, addressing process is done. In this process, it is possible to choose whether to save the group assignments to each individual address that were saved in the ballasts before the Reset.

- **Addressing:** Method to assign an address to unaddressed ECGs can be used. At the beginning of the process, it is asked if there are any ECG not addressed. In this case, each unaddressed ECG take a random number. Using these random numbers, **KNX-DALI Interface** assigns a not used address to each unaddressed ECG. This process begins after de *Reset* process, by the DCA, when the “*Search ECGs*” button is pressed, choosing “*All*”, or with the “*Search ECGs*” menu and

choosing “All ECGs” in case of using the Display. In this case, after the addressing process a complete *cyclical query* is performed. In case of **inBOX DALI 16**, as only 16 ballasts are allowed, the ballast with an address greater than 16 will automatically be assigned to a free address in the range 1...16.

- **Cyclical query:** Connected ECGs are monitored by **KNX-DALI Interface** making queries continuously to all addressed and recognized ECGs. So, if an ECGs does not responses to the queries, it is considered that a presence error is occurring. To search for new ECGs, a complete cyclical query can be performed, increasing the consulted addresses to the full range. This process can be executed using the “Search ECGs” button on the DCA and choosing “Addressed” (or with the “Search ECGs” menu and choosing “Only Addressed” on the display, if it is available). In case of choosing “All” (“All ECGs” on the display), after que complete *cyclical query*, an *Addressing* process is performed.
- **ECGs configuration:** When an ECG is recognized, **KNX-DALI Interface** configures some parameters, such as maximum and minimum dimming levels, system failure level, power on level, associated groups or other specific parameters depending on the ECG type.
- **Dimming commands:** In order to control the lighting level, **KNX-DALI Interface** sends dimming commands to the dimming points, which can be an ECG ballast (*individual addressing*) or an ECG group (*group addressing*). The time taken by the ECGs to perform the dimming process is called Fade time. With each dimming command, the Fade time is sent to the dimming point. For some specific ECG types, more data is sent, for example, colour components or colour temperature.

Note: To facilitate the commissioning, a document has been created describing the first steps when connecting a Zennio KNX-DALI Interface to the installation and detailing how to manage the DALI addressing, please refer to the product section at www.zennio.com.

1.1.4 COMPATIBLE BALLAST

KNX-DALI Interface can control ECGs following DALI standard (both DALI and DALI-2). It is particularly foreseen to control the ECG types **DT0, DT1, DT6 and DT8**. Correct operation cannot be ensured with other types of ballasts not listed in the following table.

Device type	Particular requirements for control gear	Defined in
DT0	Fluorescent lamps	IEC 62386-201
DT1	Self-contained emergency lighting	IEC 62386-202
DT6	LED modules	IEC 62386-207
DT8	Colour control	IEC 62386-209

Table 2. Classification by DALI device type

Although there are plenty of DALI ECGs in the market (most of them labelled with the DALI logo), it is observed that not all of them follow fully the DALI standard. This causes undesired behaviours in the installations (for example, addressing errors, wrong lighting levels, unexpected switch-on or switch-off or causing errors on other ballasts that do comply the DALI standard). It is recommended to check that the used ballasts are included in the [DiiA](#) database. DiiA is the organization who manages the DALI standard.

1.1.5 EMERGENCY BALLASTS

DALI standard also has a specific section regarding the emergency ballasts (also called converters), it establishes the way to make its control and maintenance through the DALI bus. Several specific commands can be sent to these ECG type:

- **Perform function test:** This test allows to check that the ballast can work correctly powering the lamp by means of the battery during a short period of time. A periodic automatic test can be configured.
- **Perform duration test:** This test checks that the duration of the battery accomplishes with the foreseen duration of the emergency fixture. It also can be configured to make periodically an automatic test.
- **Rest/Inhibit:** They are commands that avoid switching on the lamp when the power fails.
- **Start identification:** It allows to find an emergency light by means of visual or acoustic signals (they can be manufacturer defined).

This type of ballast has specific settings such as the period to do automatic function or duration tests, the prolong time in emergency mode after power reestablishment or the test timeout.

Moreover, **KNX-DALI Interface** can several queries to the converters to get its battery charge, the last tests results or the converter state (emergency mode, normal mode, charging battery, lamp error, converter error, etc).

1.2 DIMMING POINTS

The control of the different ballasts configured by **KNX-DALI Interface** is based on sending commands to the DALI bus by means of communication objects through the KNX bus, i.e. the user can control the ballasts by means of KNX commands, which the interface sends to the DALI bus with unique addresses, so that the ballasts connected to the bus can interpret and execute these actions properly. (If the device has more than one channel, this command flow can be carried out in parallel for both channels independently).

The commands on the DALI bus are applied to dimming points. A dimming point is any set of ECGs that have a common dimming functionality within a channel. Also, a distinction is made between two types of possible setpoints:

- **Individual dimming point:** The functionality applies to ECGs with a single address. There can be as many individual dimming points as there are ballasts in the channel.
- **Broadcast dimming point:** The functionality applies to any ballast that are connected to DALI bus, whether they are addressed or not.
- **Group dimming point:** The functionality applies to all ECGs associated as a DALI group. The maximum number of DALI groups is 16 per channel, as defined by the DALI standard. The ballasts may be associated to more than one DALI group.

Note: *the type of ballast that makes up a group does not necessarily have to coincide with all the ballasts that make up the group, there may be cases of use that allow inconsistencies between the type of ballast in the group and the actual type of ballast. In these cases, only the basic dimming functionality (On, Off, relative and absolute dimming) will work.*

1.3 POWER AND BUS FAILURES

This section refers to the consequences on the installation of power failures and KNX bus failures.

- **KNX bus failure:** When the KNX bus communication is interrupted, the device microcontroller will lose the power and the following values for each dimming point will be saved:
 - Dimming value
 - Colour
 - Lock status and pre-blocking regulation levels
 - Alarm status and pre-alarm regulations levels
 - Burn-in mode

In addition, it shall save the errors status previous of the bus failure, the operation time counters of each ECG and the list of detected ECGs (whether or not, at the time of the failure, they were connected to the installation). If the device has a display, it shall also save the screen locking status.

During the KNX bus failure:

- If the device has an auxiliary power supply: It keeps the DALI bus powered even if it does not make periodic status requests, and sends the dimming commands parameterised in ETS '**Dimming Value During KNX Bus Failure**' by the DALI bus. (see section 2.2.1).
- If the device has not an auxiliary power supply: The DALI bus is also fall, the ballasts will go directly to the '**Dimming Value During DALI Bus Failure**' level that has been parameterised with ETS (the same applies to those devices that do have auxiliary power supply, but it is also lost).

Note: *The transmission of control values during loss of power supply depends on whether the **Standby** mode is active for the control points. (see section 2.2.1.3)*

After the KNX bus failure:

The control levels to be set depend on the initialisation that has been parameterised for the device, as well as the blocking and alarm states. The following objects will be received via the KNX bus:

- Heartbeat
 - Standby object with disabled value
 - Dimming status objects (if you have a custom initialisation value defined)
 - Any object that has changed its value during the bus fault
- **Device auxiliary power failure (if available):** In this case, the device loses the DALI bus, sequences, single timings and flashes are stopped and will be sent via the KNX bus.
- Standby objects with disabled value
 - Power supply error object (with activated value)
 - Dimming status objects in the event of a different DALI bus fault dimming than the current dimming

Lamp dims to the set value for Dimming Value During DALI Bus Failure. (see section 2.2.1).

When the power is restored, the DALI bus is re-established and the status before the power failure is restored (provided that other functionalities such as alarms or blocking allow it).

1.4 PRIORITIES

KNX-DALI Interface has multiple functionalities that cannot always be executed simultaneously. For this reason, the priorities that the device will attend to in the event of overlapping orders have been defined.

In order to help the user understand how the device works, the **order of priority** of the actions is specified below:

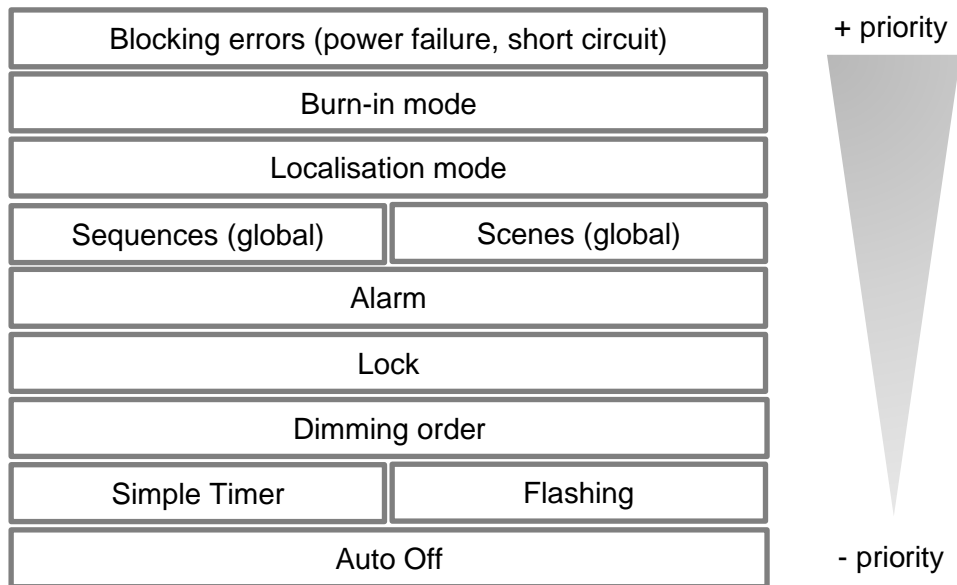

Figure 1. Priority table

On the other hand, the Standby mode priority is not included in the above table. This parameter can operate in parallel with several of the above functionalities.

Note: *the table above details **the general prioritisation** of functionality, however, it should be noted that there may be specific exceptions which are not further elaborated upon.*

1.4.1 PRIORITIES BETWEEN DIMMING POINTS

Finally, the multigroup functionality can lead to complex behaviour when combining this functionality at different regulation points. Configurations in which two simultaneous commands are given to a single ballast should be avoided, e.g. a scene affecting two groups sharing ballasts.

In case of simultaneous dimming for dimming points that share ECGs, it must be considered that the order shall be:

1. Dimming control for **Groups** (1-16)
2. Dimming control for **Individual Dimming Points** (1-64)
3. Dimming control for **Broadcast** Dimming Point.

Thus, in cases where a ballast is in several dimming points, the order that will take precedence over it, and the final state it will have, will be the last one received.

2 CONFIGURATION

The Zennio **DALI** devices, DALI BOX Interface 64 X2, DALI BOX Interface 64 v3 and inBOX DALI 16, allow a versatile and highly configurable control of the ballasts installed in their channels, which is completed with functionalities of the Zennio devices. This functionality is:

- Configuration for each **DALI channel**:
 - **Dimming times** can be set and modified via object. Up to three different dimming times can be defined.
 - **Scenes**: possibility to run and save up to 64 customised Zennio scenes.
 - **Sequences**: up to 16 customised sequences, which can be associated with the different groups. They allow, among other things, the definition of up to five steps per sequence and the type of regulation of each one.
 - **Standby**: mode that allows an external actuator to interrupt the power supply to the ballasts after the ballasts have been switched off.
 - **Error identification**: distinguishes and reports anomalies that affect the correct functioning of the device.
- Configuration for regulation points:
 - Recording of the **operating time** of each ballast.
 - Minimum and maximum brightness and dimming **limits** can be set for each dimming point.
 - For dimming the lamps:
 - One-bit objects for the **on/off switching** of each dimming point.
 - Four-bit objects for **relative regulation** for each regulation point.
 - One-byte objects for **absolute dimming** (in percentage) for dimming point.
 - Customisation of the switching on and off of the dimming points.

- **Configurable dimming:** The dimming curve type (logarithmic or linear) for DT6 ballasts and the visual perception for dimming for any ballast can be selected.
- Different dimming for **day and night mode**.
- **Simple timer and flashing:** succession of timed on/off switching of dimming points.
- **Lock:** possibility of enabling/disabling control over the groups, and of defining actions in the event of blocking and unblocking.
- **Initialisation:** customisable configuration of the initial status (when the voltage returns to the KNX bus or after downloading or restarting from ETS).
- **Special modes:**
 - **Auto Off:** allows automatic shutdown of a dimming point if the state of the dimming point remains unchanged below a certain lighting threshold for a longer time than the set time.
 - **Burn-in:** ensures that no dimming actions are performed for a configurable time in order to stabilise the behaviour of the lamp and to optimise its lifetime. This feature may be specific to certain lamp models.
- Send **dimming periodically**, for desired dimming points.
- **General functionality:**
 - **Heartbeat:** object indicating operation periodically. Objects indicating recovery are also available.
 - **Advanced configuration:** which allows to control the sending of certain commands via the DALI bus and of objects concerning emergency ballasts
 - **Manual control lock:** either to lock the Display (and associated manual control) or the manual control by button.

2.1 GENERAL

After importing the corresponding database into ETS and adding the device to the desired project topology, the configuration process is started by accessing the device parameters tab.

ETS PARAMETERISATION

When accessing the parameters tab, the general configuration screen as well as the channel configuration tab are displayed. From the general configuration screen, all necessary functions can be activated/deactivated.

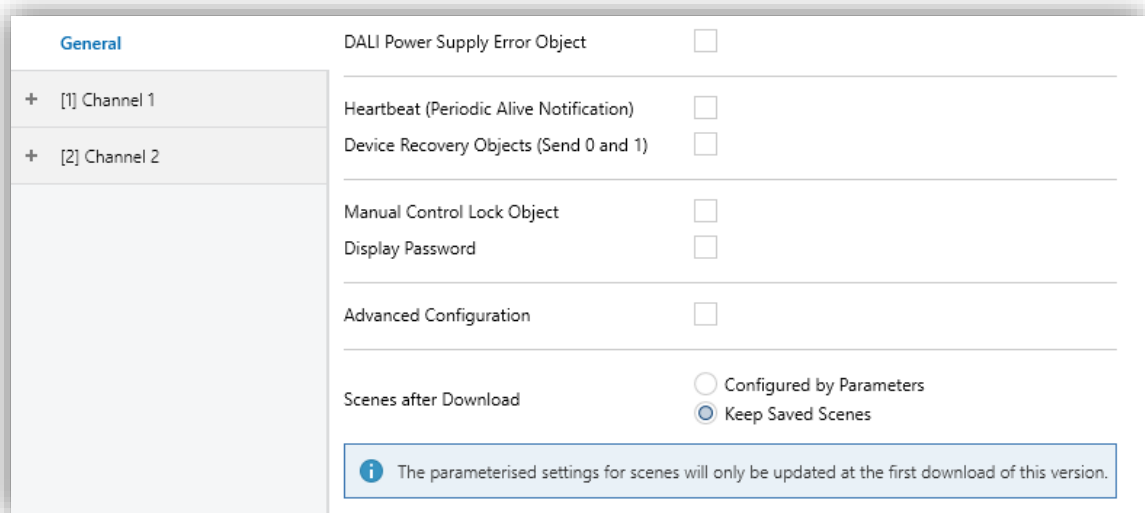

Figure 2. General configuration window

Note: The images shown in this document correspond with DALI BOX Interface 64 X2, that has two channels. For the rest of devices in the family, only one channel is shown.

- **DALI Power Supply Error Object** [*enabled / disabled*]: An object to notify the auxiliary power supply error is shown.

Note: This error is only available for devices having auxiliary power supply. Thus, it is not available in inBOX DALI 16, that is fed by means of KNX bus.

- **Heartbeat** [*enabled / disabled*]: One bit object (“**[Heartbeat] Object to Send ‘1’**”) will send an “1” periodically to notify that the device is working.

Figure 3. Heartbeat

Note: After download or after bus failure, first sending is delayed up to 255 seconds, to avoid bus saturation. The following sendings keep the parameterised period.

- **Device Recovery Objects (Send 0 and 1) [enabled / disabled]:** Two objects (“[Heartbeat] Device Recovery”) are activated and they will be sent with values “0” and “1”, respectively, when the device starts working. It is possible to include a **delay [0 ... 255][s]** in the sending.

Figure 4. Device recovery objects

Note: After download or after bus failure, the sending is delayed up to 6,35 seconds additional to the parameterised delay to avoid bus saturation.

- **Manual Control Lock Object [enabled / disabled]:** An object (“Manual Control Lock”) is shown. It allows to lock the display (if the device has it) or the manual control button (for inBOX DALI 16).

Figure 5. Manual Control Lock Object

When this parameter is enabled, two new parameters are shown:

- **Object Polarity [0 = Unlock; 1 = Lock / 0 = Lock; 1 = Unlock]:** it defines if the lock/unlock is done when values of “1”/”0” are received or vice versa.
- **Initialisation [Last Value / Locked / Unlocked]:** It indicates the status of the manual control lock after bus failure or after configuration. “Last Value” after configuration means Unlocked.

- **Display password** [*enabled / disabled*]: a password is set which will block part of the functionality of the Display by means of a 4-digit numerical code. (See 3.2.2.1 section).



Figure 6. Display password

- **Advanced Configuration** [*enabled / disabled*]: It creates a specific menu.
- **Scenes after Download** [*Configured by Parameters / Keep Saved Scenes*]: It defines if the scenes values considered is taken from parameters or the previous values before download.

Note: With “Keep Saved Scenes”, after the first download or after a download where the version is changed, the values considered will be the parameters’ ones. If in a parameterisation the number of scenes is increased, it is mandatory to select “Configured by Parameters” to ensure the correct working of scenes.

2.1.1 ADVANCED CONFIGURATION

When the parameter **Advanced Configuration**, following window will be shown:



Figure 7. Advanced Configuration

Note: It is recommended not to activate these options, unless having deep knowns of DALI standard.

These options are configurable:

- **Colour Activation Configuration** [['Automatic Activation' mode enabled \(recommended\)](#) / [Activate colour first, then change light level](#) / [Change the light level first, then activate colour](#)]: In a normal way, **KNX-DALI Interface** operates with colour automatic activation, but this parameter represents a corrective measure for ballasts not working correctly. Some ballasts not supporting properly this DALI Standard characteristic have been found, then it is allowed to perform an advanced control in order to reach a desired behaviour of these ballasts.
- **Send OFF after RESET command** [[enabled](#) / [disabled](#)]: During a facility initialisation, the ballasts are reset to their default values. The DALI standard defines that, after a reset, the ballasts are dimmed at 100%. This parameter allows all ballasts to be switched off after a Reset, so that they are not kept on, when the installation is initialised.
- **Send Emergency Status Objects when a Status Change Occurs in an Emergency ECG** [[enabled](#) / [disabled](#)]: The enablement of this parameter is recommended in case of use a BMS (Building Management System).

2.2 CHANNEL X

DALI BOX Interface 64 v3 and inBOX DALI 16 has one channel each, meanwhile **DALI BOX Interface 64 X2** has two channels; ballasts can be connected to each of them by means of the DALI bus. When the option “[x] Channel x” is selected on the left part of the ETS window the Configuration, ECGs and Dimming Points tabs are shown.

2.2.1 CONFIGURATION

ETS PARAMETERISATION

The Configuration tab has the following parameters:

Figure 8. Channel configuration tab

- **Name:** It is the desired name of the channel (12 characters).
- **Fade Times:** Three fade times can be defined. They will apply to the regulations of the channel.
 - **Fade Time 1** [*Immediate / 0.7 ... 2 ... 90.5*] [s].
 - **Fade Time 2** [*Immediate / 0.7 ... 4 ... 90.5*] [s].
 - **Fade Time 3** [*Immediate / 0.7 ... 8 ... 90.5*] [s].
 - **Fade Time Objects** [*enabled / disabled*]: Three objects “[Cx] Fade Time X” are enabled to make possible to change the parameterized fade times.

Note: These fade times refer to all regulations, independently of the initial and final values (i.e., it takes the same time a dimming change from 0% to 100% and from 10% to 15%).

Three independent functions can be configured: “Scenes”, “Sequences” and “Standby”. These functions are detailed in the following sections.

2.2.1.1 SCENES

The scene function makes it possible to define scenes, i.e. specific dimming environments that can be activated by sending their activation values through a 1-byte object.

Up to **64 scenes** can be configured in **KNX-DALI Interface**, which can be assigned to the enabled dimming points.

ETS PARAMETERISATION

Once this function is enabled a new object is shown (“**[Cx] Scene Control**”) to executed and save a specific scene.

- **Scenes Number** [0... 64]: Up to 64 scenes can be enabled and configured.

Figure 9. Scenes enabling parameter

The “Scenes” tab has a secondary tab (“*[x] Scene x*”) that allows to fix the parameters of a scene.

Dimming Points	Associate	Dimming Value / Channels RGB	Channel W / Colour Temperature	Fade Time
[B] Broadcast	<input type="checkbox"/>			

Figure 10. Scene configuration

- **Scene Number** [**1 to 64**] (**0 = Disabled**) [0... 64]: It defines the value of the object “**[Cx] Scene Control**” that will launch or save the scene.
- **Name**: Text of up to 12 characters to identify the scene.

- Available dimming points:
 - **Associate** [*enabled / disabled*]: It defines the scene influence on the dimming point.
 - **Dimming Value / Channels RGB**: This parameter will have different possible values depending on the dimming point type (Normal, LED, RGBW or Colour Temperature) (see section 2.2.4):
 - Normal, LED → **Dimming Value** [*0...100*] [%]
 - RGBW → **RGB Channels** [*#000000...#FFFFFF*]
 - Colour Temperature → **Dimming Value** [*0...100*] [%]
 - **Channel W / Colour Temperature**:
 - RGBW → **Channel W** [*0...255*]
 - Colour Temperature → Colour Temperature [*1000...3000...20000*] [K]
 - **Fade Time** [*Immediate / 0.7 ... 2 ... 90.5*] [s]: It defines the fade time of the dimming point once the scene is launch.

Note: Scenes are intended to set a specific regulation value for the loads by using a single control command. Thus, if orders that share loads are selected, the scene will execute the orders in the order set by the table.

2.2.1.2 SEQUENCES

This function allows to define up to **16 sequences**, which can contain up to 5 actions on the configured dimming points. These sequences can be executed simultaneously, i.e. the starting of a sequence does not interfere with the previous executed sequence.

When this function is enabled, these objects are shown in ETS:

- “[Cx] Sequence Control”:
- It is used to start or stop the execution of the sequence, as it is shown in the following table.

Sequence number	Stop	Start
1	0	128
2	1	129
...
64	63	191

Table 3. Sequence control

- “[Cx] Sequence Launcher”: It is like the scene control object, but it does not allow to save.

Sequence number	Start
1	0
2	1
...	...
64	63

Table 4. Sequence control

- “[Cx] Stop Sequences”: it is a one bit object to stop all the sequences when any value is received.

ETS PARAMETERISATION

Up to 16 sequences can be enabled by means of the parameter:

- **Sequences Number [0 ... 16]**: it allows to enable a quantity of sequences.

The screenshot shows a window titled 'ENABLE SEQUENCES'. Inside, there is a label 'Sequences Number' followed by a dropdown menu that currently displays the value '0'.

Figure 11. Sequence enabling parameter

Each enabled sequence can be configured in the following window:

The screenshot shows a configuration window for a sequence. It includes the following fields and controls:

- Sequence Number [1 to 64] (0 = Disabled): 0
- Name: [Empty text field]
- Cyclic:
- Next Sequence: [Dropdown menu showing '-']
- Send Dimming Status during Sequence:

Below these fields is a table for defining actions:

Actions	Dimming Point	Dimming Value / Channels RGB	Channel W / Colour Temperature	Fade Time	Time to Next Action	Time to Next Action Units
Action 1	-					

Figure 12. Sequence configuration

- **Sequence Number [1 to 64] (0 = Disabled) [0 ... 64]:** It defines the value of the objects “[Cx] Sequence Control” or “[Cx] Sequence Laucher” that will launch the sequence.
- **Name:** Text of up to 12 characters to identify the sequence.
- **Cyclic [enabled / disabled]:** If it is enabled, the sequence will start again after its finish. When it is enabled, the parameter Next Sequence is not shown.
- **Next Sequence [- / Sequence 1 ... Sequence 16]:** After finishing the current sequence, this sequence will start.
- **Send dimming Status during Sequence [enabled / disabled]:** If it is enabled, the status objects will be updated on each action of the sequence.

Up to **five actions** can be configured for the sequence:

- **Dimming Point [Disabled / Group: x / Individual: ECG x / Broadcast]:** It defines the dimming point affected by the action.
- **Dimming Value / Channels RGB:** This parameter will have different possible values depending on the dimming point type (Normal, LED, RGBW or Colour Temperature) (see section 2.2.4.1):
 - Normal, LED → **Dimming Value [0...100] [%]**
 - RGBW → **RGB Channels [#000000...#FFFFFF]**
 - Colour Temperature → **Dimming Value [0...100] [%]**
- **Channel W / Colour Temperature:**
 - RGBW → **Channel W [0...255]**
 - Colour Temperature → **Colour Temperature [1000...3000...20000] [K]**
- **Fade Time [Immediate / 0.7 ... 2 ... 90.5] [s]:** It defines the fade time of the dimming point once the scene is launch.
- **Time to Next Action [1 ... 10 ... 255]:** Time passing between actions starts.
- **Time to Next Action Units [s / min]:** Units of the previous parameter.

2.2.1.3 STANDBY

This is a functionality included in the **KNX-DALI Interface**, which is able to send a KNX object to interrupt the power supply to the ballasts after a certain timeout period has elapsed. This allows the use of an external actuator to interrupt the power supply to the ballasts, thereby reducing power consumption. The object will be sent again (with the inverse value) as soon as a switch-on of the dimming points associated with this standby is requested. Note that the use of this function may cause the dimming point switching-on a little longer than expected.

To use this function correctly, **KNX-DALI Interface** must be associated with an actuator. In addition, the output of the actuator must be able to close or open the ballast power supply. This is shown in the following diagram:

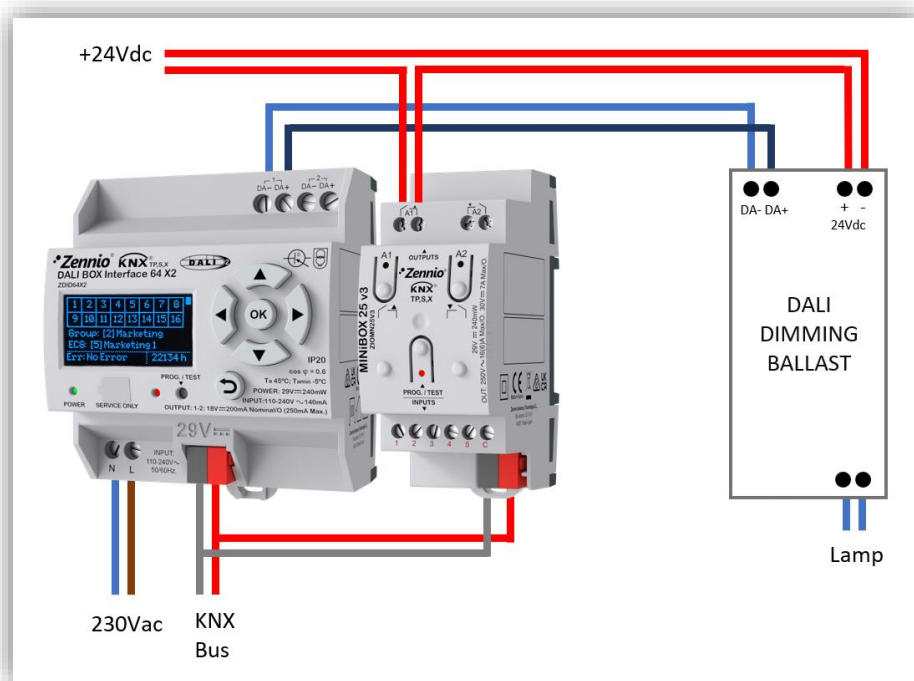

Figure 13. Standby connection diagram

During Standby mode, errors on the DALI ballasts cannot be detected. When the device starts working, Standby is inactive to ensure that ballasts are fed during the initialisation. Other cases of inactivation of Standby are:

- **DALI bus failure** (Auxiliary power supply failure or DALI short-circuit)
- Beginning or ending of **Burn-in Mode** (see section 2.2.4.4.8)
- New **ballast configuration** through DCA or Display (if applicable).

ETS PARAMETERISATION

Once the Standby functionality is enabled, the following window will be shown:

ENABLE STANDBY

Standby Number

i Please, check that all ECGs are powered during the group associations stage.

Delay to Send DALI Commands After Standby Off x 50 ms

Figure 14. Standby enabling

These parameters can be configured:

- **Standby Number** [0 ... 16]: It defines the quantity of standby objects available.
- **Delay to Send DALI Commands After Standby Off** [10, 11 ... 20] [x 50 ms]: It is the time of the delay between the Standby object sending and the beginning of the DALI communication to the associated ballasts.

These parameters can be configured:

General

Time for Activation

s min

Object Polarity

0 = Standby Off; 1 = Standby On

0 = Standby On; 1 = Standby Off

AVAILABLE ECGS

Associate ECG 1

General

- [1] Channel 1

Configuration

+ ECGs

+ Dimming Points

- Standby

Standby 1

+ [2] Channel 2

Figure 15. Standby parameters

- **Time for Activation** [1 ... 30 ... 255] [s / min]: It defines the time while all associated dimming points are off before activating the Standby.
- **Object Polarity** [0 = Standby Off; 1 = Standby On / 0 = Standby On; 1 = Standby Off]: It defines the polarity of the object.
- **Available Dimming Points**: ECGs associated with this standby function.

2.2.1.4 GENERAL FUNCTIONS

In the lower part of the Configuration tab, some General Functions can be enabled:

GENERAL FUNCTIONS

Dimming Value During KNX Bus Failure No Change Defined Value

Error Objects

Figure 16. General Functions

- **Dimming Value During KNX Bus Failure** [*No Change / Defined value*]: It defines the dimming value of the ballasts connected to the DALI bus during a KNX bus failure. If “Defined Value” is selected, parameter **Value** [0 ... 100] [%] can be configured. It is not available in devices not having auxiliary power supply.

Note: *The value configured in this parameter will be sent to all ballasts connected to the DALI bus (although, they are not associated to any dimming point) on KNX bus failure, and last fade time used each the dimming point will be used*

- **Error objects** [*enabled / disabled*]: **KNX-DALI Interface** allows to enable the objects to be sent to the KNX bus on errors and the use of a diagnostics object (1 or 2 bytes, as defined in the KNX Standard).

Error Objects

Short Circuit

Presence Error

ECG Error

Lamp Error

Diagnostic -

Figure 17. Error Objects

- **Short Circuit** [*enabled / disabled*]: It activates the object “[Cx] Short Circuit” to notify the presence of a short circuit in the DALI bus.
- **ECG Presence** [*enabled / disabled*]: It activate the object “[Cx] Error: ECG Presence” and the ballasts objects “[Cx] [ECG x] [] Presence Error” to notify the absence of a recognized ballast.

- **ECG Error** [*enabled / disabled*]: It activate the object “[Cx] Error: ECG” and the ballast objects “[Cx] [ECG x] [] ECG Error” that notify the error that each ballast may present in the DALI bus.
- **Lamp Error** [*enabled / disabled*]: It activate the object “[Cx] Error: Lamp” and the ballast objects “[Cx] [ECG x] [] Lamp Error” which report the failure of the load controlling the ballast.
- **Diagnostics** [*- / ECG Diagnostics (1 byte) / ECG and Group Diagnostics (2 bytes)*]: It allows to use the two types of objects foreseen by the KNX standard to manage the DALI ballast diagnostics. It activates the object “[Cx] ECG Diagnostic” or “[Cx] ECG and Group Diagnostic”.

Note: *KNX-DALI Interface will perform the necessary status requests to obtain these diagnostic values, however, not all ballasts have the functionality to indicate these types of errors enabled.*

2.2.2 ECGS

For each channel, after configuring its parameters, connected ballast must be enabled. In the ECGs tab, a table is shown to make possible, for each ballast, enable it, define if is a converter and define its name.

ETS PARAMETERISATION

General		ENABLEMENT			
[1] Channel 1		ECGs	Enable	Emergency (DT1 - part 202)	Name
Configuration		ECG 1	<input type="checkbox"/>		
ECGs		ECG 2	<input type="checkbox"/>		
+ Dimming Points		ECG 3	<input type="checkbox"/>		
		ECG 4	<input type="checkbox"/>		
		ECG 5	<input type="checkbox"/>		
+ [2] Channel 2		ECG 6	<input type="checkbox"/>		
		ECG 7	<input type="checkbox"/>		

Figure 18. ECGs enablement

- **Enable** [*enabled / disabled*]: Up to 64 ballasts can be enabled (16 in case of inBOX DALI 16). It is not mandatory to use correlative numbers.
- **Emergency (DT1 – part 202)** [*enabled / disabled*]: Each ballast can be enabled as emergency ballast (DT1) or converter, once the ballast is enabled. If this parameter is enabled, some objects are shown: “[Cx][ECG x][] Converter

Control”, “[Cx][ECG x][] Test Control”, “[Cx][ECG x][] Converter Status” and “[Cx][ECG x][] Converter Test Result” (see section 2.2.2.1).

- **Name:** Text of up to 12 characters to define the name of the ballast. This name will be shown in the object names, on the DCA, on the Display (if applicable) and at the left part of the configuration tab.

The following section describes the parameters of each ECG enabled.

2.2.2.1 [X] ECG X

Parameterisation of each enabled ballast is done in the following window. Some of the parameters are only applicable to converters or emergency ballasts.

ETS PARAMETERISATION

Figure 19. ECG configuration

These parameters can be configured:

- **Name:** Text of up to 12 characters to define the name of the ballast. It is the same name that shown in the ECGs enablement tab and its table.
- **Dimming Value During DALI Bus Failure** [[No Change](#) / [Defined value](#)]: In this case, on the ballast's configuration, a value will be set at which the dimming points will immediately dim on DALI bus failure (short circuit in the DALI network or loss of power supply to the DALI channel. If the "Set Value" option is selected, an additional parameter is shown:
 - **Dimming Value** [[0 ... 100](#)] [%]: It is the value to dim during DALI bus failure.
- **Enable Operation Time Counter Object** [[enabled](#) / [disabled](#)]: It activates a counter of the operating time of the ballast by means of an object "[Cx][ECGx][**Operation Time**". It is considered the time while the ballasts have a regulation higher than 0%. This object can be written (when the lamp or the ballast is changed) or it can be reset through the Display (if available).

OPERATION TIME

Enable Operation Time Counter Object

Operation Time Object Units s h

Operation Time Initial Value Keep Value Defined Value

Operation Time Alarm

Figure 20. Operation Time

- **Operation Time Object Units** [[s](#) / [h](#)]: It is the units (hours or seconds) of the counter object.
- **Operation Time Initial Value** [[Keep Value](#) / [Defined Value](#)]: It defines the initial value of the counter after programming. If "Defined Value" is selected, parameter **Value** [[0...596523](#)] [[h](#)] is shown to define value of the counter after download.

Note: For emergency ballasts, operation time considers the time while the ballast is switched on or dimming not in emergency mode. Tests are not considered in the counter.

- **Operation Time Alarm** [*enabled / disabled*]: It defines the operation time of the ballast before triggering an alarm. When it is enabled, another parameter defines this time, in hours: Value (0 = Disabled) [0 ... 596523] [h].

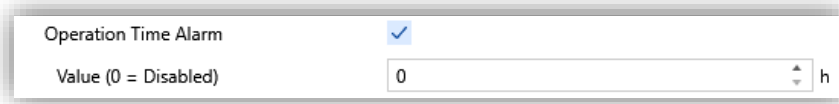

Operation Time Alarm	<input checked="" type="checkbox"/>
Value (0 = Disabled)	<input type="text" value="0"/> h

Figure 21. Operation Time Alarm

In case of Emergency ballasts, these additional parameters are shown:

- **Dimming Value in Emergency Mode** [0 ... 100] [%]: It defines the dimming value while the ballast is in emergency mode.
- **Prolong Time on Recovery** [0 ... 20] [min]: It defines the time while the ballast remains in emergency mode after recovering the power supply.
- **Function Test Interval** [0 ... 255] [days]: It defines the periodicity of the automatic execution of the test that checks the correct working of the ballast. Moreover, it is the delay of the first test after configuration.
- **Duration Test Interval** [0 ... 52] [weeks]: It defines the periodicity of the automatic execution of the test that checks the correct duration of the battery. Moreover, it is the delay of the first test after configuration.
- **Partial Duration Test Interval** [0 ... 52] [weeks]: It defines the periodicity of the automatic execution of the test that make an estimation of the health of the battery.
- **Partial Duration Test Duration (0 = Disabled)** [0 ... 60] [min]: It defines the time that elapses the test that check the battery health.
- **Test Execution Timeout (0 = 15 min)** [0 ... 255] [days]: It defines the time in which the ballast will try to do the test before reporting an error of execution.
- **Dimming Point Capabilities** [*enabled / disabled*]: It enables that the ballast will be controlled like any other ballast with regulation functions.

2.2.3 DIMMING POINTS

Once the ballasts have been enabled, the dimming points tab allows to define the groups and individual dimming points to be controlled in the DALI installation. It is shown on the next window:

Figure 22. Example of Dimming Points table. ECGs 4, 11 and 16 enabled.

Important: With **KNX-DALI Interface**, each ECG can be controlled, being assigned as:

- **Individual** dimming point, if enabled.
- **Groups**, with which it may be associated.
- **Broadcast**, which control all ballast. (It is not allowed to disable).

If a dimming point is enabled, either group dimming point or individual dimming point, a secondary tab will include its parameters. The way to configure it is similar for both individual, group or broadcast dimming points.

- Dimming Status for Dimming Points [Average Dimming Value of all Included ECGs / Last Value Received in Dimming Point]**: Since it is possible to configure the system so that a ballast can belong to several dimming points (including broadcast), it is possible to parameterise the sending of the status of each dimming point as follows:

- As “Average Dimming Value of all Included ECGs”, which will send the status as an average of the regulation values of all the dimming points that compose it.
- As “Last Value Received in Dimming Point”, which will only update the status object when directly regulating that dimming point, or whenever the entire regulation point is changed by being completely included within another dimming point.

Note: the mean value shall only be sent for the dimming value, in no case shall mean values of colour states (Colour Temperature, RGB or RGBW) be considered.

An example is shown below to assist the user's understanding:

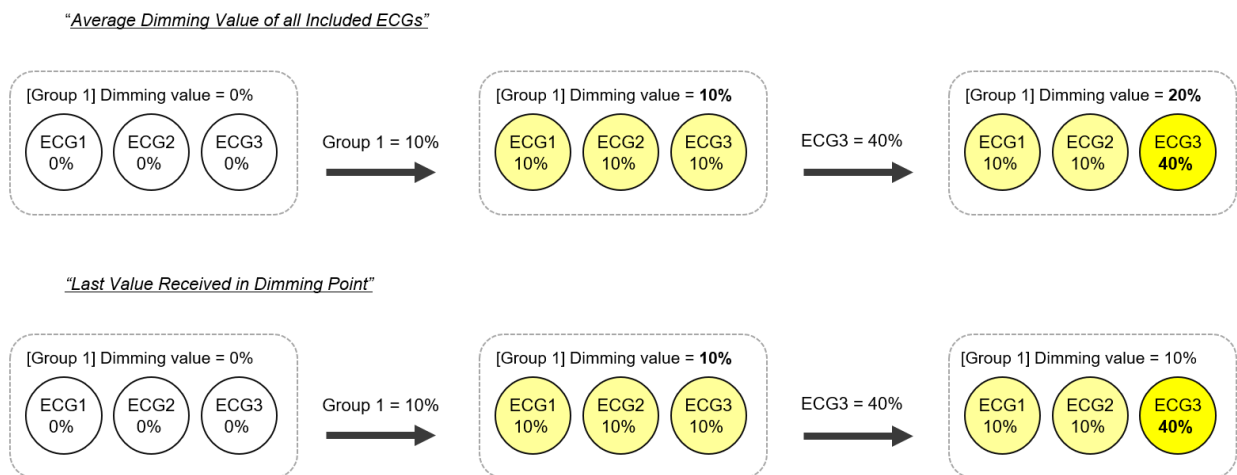

Figure 23. Average and last value status example

- Send Dimming to bus DALI Periodically [enabled / disabled]**: It is possible to send to the **DALI bus** the dimming point regulation periodically so that, in case of ballast power supply lost and recovery, they will recover the correct dimming status.

2.2.4 [GX] GROUP X / [IY] ECG Y

The following window allows to configure the dimming point:

ETS PARAMETERISATION

Figure 24. Dimming Point configuration

This tab allows to configure the dimming point and its functionality. When the dimming point is enabled, following objects will be activated:

- “[Cx][ECG x / Group x / Broadcast] On/Off”
- “[Cx][ECG x / Group x / Broadcast] On/Off (Status)”
- “[Cx][ECG x / Group x / Broadcast] Absolute Dimming”
- “[Cx][ECG x / Group x / Broadcast] Relative Dimming”
- “[Cx][ECG x / Group x / Broadcast] Dimming Value (Status)”

The parameters:

- **Name:** Text of up to 12 characters to define the name of the dimming point.

2.2.4.1 DIMMING POINT TYPE

- **Dimming Point Type** [[Normal](#) / [LED \(DT6 – part 207\)](#) / [RGB \(DT8 – part 209\)](#) / [RGBW \(DT8 – part 209\)](#) / [Temperature Colour \(DT8 – part 209\)](#)]: Ballast type of the dimming point to enable the suitable objects to control it. If it belongs to a group of ballasts, it is recommended that all the ballasts will be of the same type to be regulated correctly. Four types of ballasts are allowed:

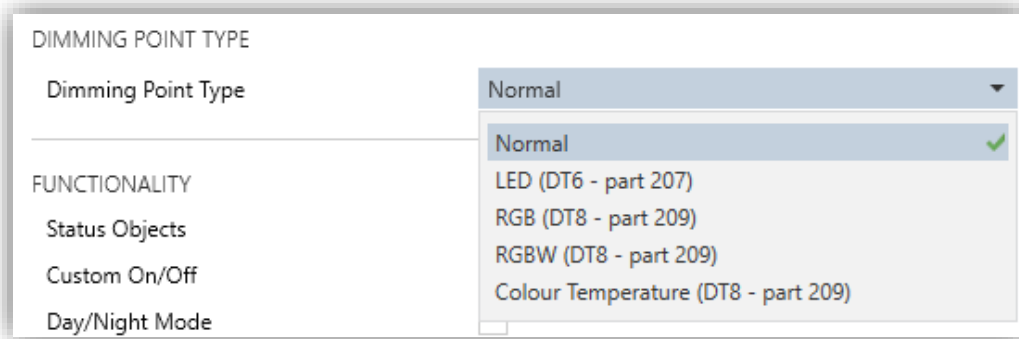

Figure 25. ECG types

- **Normal:** It is a generic ballast type (originally DT0 – Part 201 or fluorescent lamp), so it can be controlled with switching and dimming commands, also valid for other ballast types. It is the only ballast type with Burn-In functionality.
- **LED (DT6 – part 207):** It comprises the LED drivers.
- **RGB (DT8 – part 209):** It comprises the RGB type, that allow configure:
 - **Colour Objects** [[RGB Object](#) / [R + G + B Object](#)]: which are selected by ticking one of these two options:

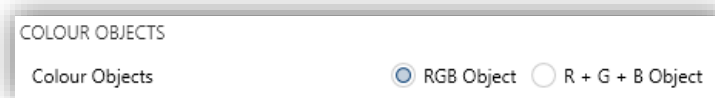

Figure 26. RGB Object

- **RGBW (DT8 – part 209):** They are colour ballasts RGB or RGBW, in case of having also white channel. In this case the control and status objects can be configured.
 - **Colour Objects** [[RGBW Object](#) / [RGB Object + W Object](#) / [R + G + B + W Object](#)]: In case of RGB/RGBW ballast, it can be selected the type of objects to control and supervise them.

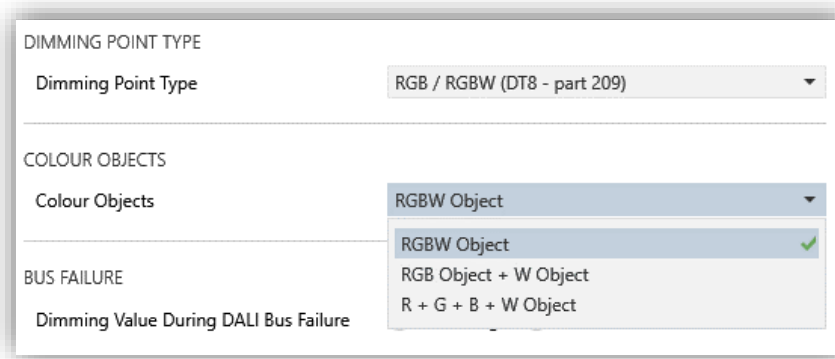

Figure 27. RGB/RGBW objects

- **RGBW Object:** Two 6-byte objects are activated (DPT 251.600), one for control and another for status. It includes the components of each colour component and one bit to consider each component.
 - **RGB + W Objects:** Four objects are activated, two for control and another two for status; in this case, component RGB and component W are split. The RGB object has 3 bytes (DPT 232.600) to define each component and the W object has 1 byte (DPT 5.001).
 - **Objects R + G + B + W:** In this case, 8 communication objects are activated; four of them for regulation and the other four for status. These objects have 1 byte (DPT 5.001) to control each component separately.
- **Colour Temperature (DT8 – part 209):** If ballast if Colour Temperature type, **KNX-DALI Interface** can control the colour temperature through four objects (three for control and one for status).
- One of the control objects has 2 bytes (DPT 7.600) and it allows to define the colour temperature in Kelvin.

Note: *It must be considered that the regulation values of this object will be restricted by the limits parameterized for the dimming point (see section 2.2.4.2).*

- A relative regulation object (4 bits) and an absolute regulation object (1 byte) allow to control the colour temperature. The absolute object can be

regulated in a range of 0% to 100% (where 0% is the hottest temperature and 100% is the coolest). It must be considered that lower values belongs to warn colours (up to 1000 K) and higher values correspond to cool colours (up to 20000 K), as it is shown in the scale:



Figure 28. Colour temperature scale

2.2.4.2 LIMITS

Limits configuration can be done on the following tab:

LUMINOSITY LIMITS	
Minimum Luminosity Level	<input type="text" value="1"/> x 0.1%
Maximum Luminosity Level	<input type="text" value="1000"/> x 0.1%
DIMMING LIMITS	
Minimum Dimming Value	<input type="text" value="0"/> %
Maximum Dimming Value	<input type="text" value="100"/> %
COLOUR TEMPERATURE LIMITS	
Maximum Physical Value	<input type="text" value="10000"/> K
Minimum Physical Value	<input type="text" value="1000"/> K
Maximum Dimming Value	<input type="text" value="10000"/> K
Minimum Dimming Value	<input type="text" value="1000"/> K

Figure 29. Limits

The **Luminosity Limits** are restrictions to the regulation commands sent to the DALI bus. These values do not influence the KNX status objects. They can be configured with the parameters:

- **Minimum Luminosity Level** [1 ... 100] x 0.1%: It is the limit that the ballast is not able to overpass. Normally it is configured with the physical limit of the ballast, i.e. the value below which it could not do correct dimming.
- **Maximum Luminosity Level** [1 ... 1000] x 0.1%: It is an upper limit to the regulations sent to the DALI bus. It can represent a limit to economize the consumption of energy.

The **Dimming Limits** are restrictions to the KNX control objects. So, any value out of limits will be replaced by the limits. They can be configured with the parameters:

- **Minimum Dimming Value** [0... 100] %: It is the lowest dimming value considered when a dimming object is received. Any value below this limit will be replaced by the limit, unless it is 0%. Although limit is greater than 0%, the 0% value will be always considered.
- **Maximum Dimming Value** [1 ... 100] %: It is the highest dimming value considered when a dimming object is received. Any value above this limit will be replaced by the limit.

Note: *the limits to be applied, in case of dimming points sharing ballasts with other dimming points with different limits, shall be the least restrictive limits. If a particular limit is to be applied to a single ballast, it must be enabled as an individual dimming point, regardless of whether it belongs to a group.*

In case of Colour Temperature dimming points, **Colour Temperature Limits** can be parameterised:

- **Maximum Physical Value** [1000... 10000 ... 20000] K: It is the colour temperature of the cold component of the lamp.
- **Minimum Physical Value** [1000 ... 20000] K: It is the colour temperature of the warm component of the lamp.
- **Maximum Dimming Value** [1000... 10000 ... 20000] K: It is the highest colour temperature considered when object is received. Any value above this limit will be replaced by the limit.
- **Minimum Dimming value** [1000 ... 20000] K: It is the lowest colour temperature value considered when object is received. Any value below this limit will be replaced by the limit.

2.2.4.3 SWITCH & DIMMING

The parameterisation of the switching and dimming control is done on the following window:

ON/OFF (1 bit)

On Value Last On Value Defined Value

Reach Maximum after a Switch On Order if It Is Already On

On/Off Fade Time

RELATIVE DIMMING (4 bits)

Relative Dimming Fade Time

Allow Switching On via Relative Dimming

Allow Switching Off via Relative Dimming

ABSOLUTE DIMMING (1 byte)

Absolute Dimming Fade Time

Figure 30. Switch and Dimming

The parameters of switching functionality are:

- **On Value** [[Last On Value](#) / [Defined Value](#)]: It defines the dimming value of the dimming point when the object “[Cx][ECG x / Group x][] On/Off” receives a “1”.

With the option “[Last Value](#)”, the parameter **Reach Maximum after a Switch On Order if It Is Already On** [[enabled](#) / [disabled](#)] is shown.

With the option “[Defined Value](#)”, following parameters are shown:

- **Dimming Value** [[0...100](#)] %
- **Channels RGB** [[#000000...#FFFFFF](#)]: (only for RGB/RGBW type dimming point) They are the RGB components that can be chosen through a colour selection dialog.
- **Channel W** [[0...255](#)]: (only for RGB/RGBW type dimming point). It is the W component value, and it can be selected through an slider control.
- **Colour Temperature** [[1000... 3000 ... 20000](#)] K: (only for Colour Temperature type dimming point).
- **On/Off Fade Time** [[At Once](#) / [Fade Time 1](#) / [Fade Time 2](#) / [Fade Time 3](#)]: It allows to define the fade time of these switching operations.

The parameters to define the relative regulation are:

- **Relative dimming Fade Time** [*At Once / [Fade Time 1](#) / [Fade Time 2](#) / [Fade Time 3](#)*]: It allows to define the fade time of relative dimming operations.
- **Allow Switching On via Relative Dimming** [*[enabled](#) / [disabled](#)*]: It allows to switch on a dimming point though relative dimming orders.
- **Allow Switching Off via Relative Dimming** [*[enabled](#) / [disabled](#)*]: It allows to switch off a dimming point though relative dimming orders. If it is not enabled, the minimum dimming value that can be reached using relative dimming commands is the **Minimum Dimming Value**.

The parameter to define the absolute regulation is:

- **Absolute dimming Fade Time** [*At Once / [Fade Time 1](#) / [Fade Time 2](#) / [Fade Time 3](#)*]: It allows to define the fade time of absolute dimming operations.

2.2.4.4 FUNCTIONALITY

In this section, the rest of dimming point functionality is described.

FUNCTIONALITY	
Status Objects	<input checked="" type="checkbox"/>
Custom On/Off	<input type="checkbox"/>
Day/Night Mode	<input type="checkbox"/>
Timers	<input type="checkbox"/>
Lock	<input type="checkbox"/>
Alarm	<input type="checkbox"/>
Custom Initialisation	<input type="checkbox"/>
Modes	<input type="checkbox"/>

Figure 31. Dimming Point Functionality

2.2.4.4.1 Status Objects

- **Status Objects** [*[enabled](#) / [disabled](#)*]: It activates several objects to send the status of the dimming point:
 - A binary object (On/Off)
 - A 1-byte object, to indicate que dimming value.
 - Objects for RGBW channels and Temperature Control.

ETS PARAMETERISATION

The **Status Objects** tab is shown on ETS:

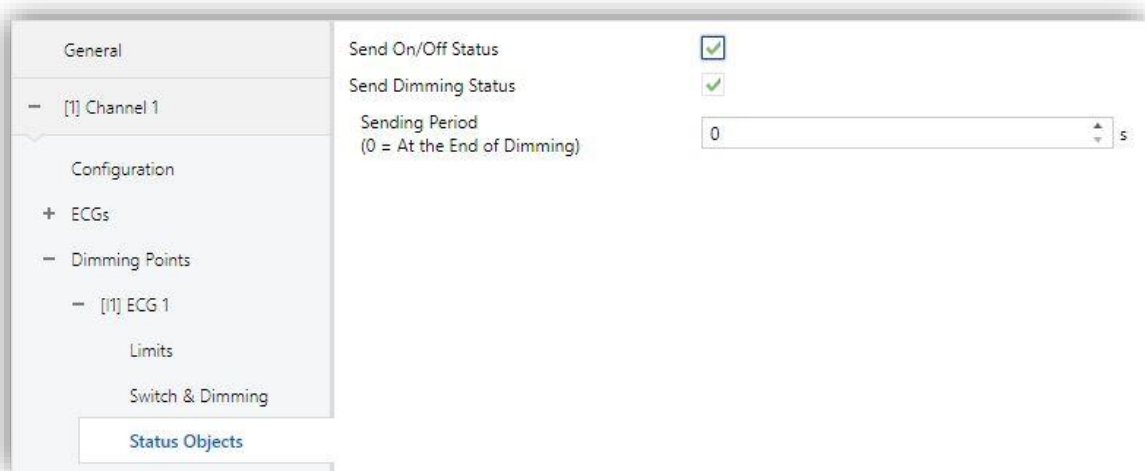

Figure 32. Status Objects

- **Send On/Off Status** [*enabled* / *disabled*]: It allows the sending of the object “[Cx][ECG x / Group x] On/Off (Status)” with value “1” when the dimming value is higher than 0% (for both, a dimming in progress and a stopped dimming) and “0” when the dimming value is 0%. Each time the On/Off control object is sent, the status object will response.
- **Send Dimming Status** [*enabled* / *disabled*]: It enables the percentage value status sending, it is sent always a regulation is performed. In case of DT8 ballasts (RGBW / TW), it has associated the specific status objects for RGBW and colour temperature. When this parameter is enabled, the following parameter is shown:
 - **Sending Period (0 = At the End of the Dimming)** [*0 ... 90*] s: It defines a cyclical sending of the status object during regulations. In case of select “0” , the status object is sent at the end of the regulation.

2.2.4.4.2 Custom On/Off

- **Custom On/Off** [*enabled* / *disabled*]: It allows to have an additional On/Off control for the dimming point and, then, an additional control object to switch-on or switch-off the ballasts. The dimming values and fade times can be defined for “On” and “Off”.

This additional control allows to customise the lighting level for the ‘On’ and ‘Off’ states and to set whether the switching should be immediate or with a certain dimming time.

Custom On/Off can be parameterized in the following dialog:



Figure 33. Custom On/Off

Behaviour at the reception of “1” or “0” can be defined with the parameters:

- **Dimming Value at On** [*0...100*]: It represents the dimming value of the dimming point when a “1” is received from the object “[Cx][ECG x / Group x][Custom On/Off”.
- **Fade Time at On** [*At once / Fade Time 1 / Fade Time 2 / Fade Time 3*]
- **Dimming Value at Off** and **Fade Time at Off** are similar to these but in case of receiving a “0”.

2.2.4.4.3 Day/Night Mode

- **Day/Night Mode** [*enabled / disabled*]: It has a similar behaviour to **Custom On/Off**, but the parameters can be different depending on the Day/Night mode. This functionality allows to switch-on and switch-off the dimming point through a 1-bit object and switch between two lighting modes with a 1-bit object.

When this option is enabled, two 1-bit objects are activated: “[Cx][ECG x / Group x][Day/Night Mode On/Off” and “[Cx][ECG x / Group x][Day/Night Mode”.

The following tab is activated to configure the functionality:

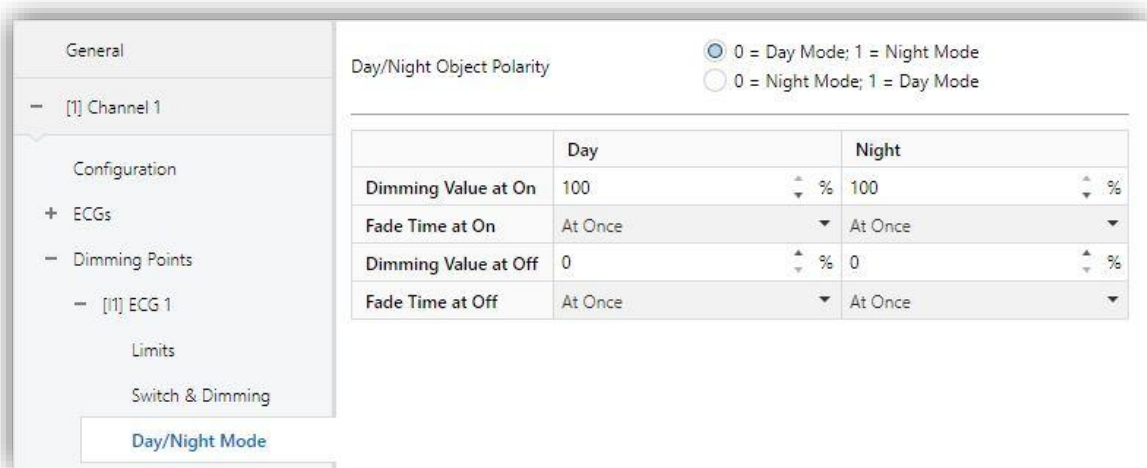

Figure 34. Day/Night

- **Day/Night Object Polarity** [0 = Day Mode; 1 = Night Mode / 0 = Night Mode; 1 = Day Mode]: It allows to configure the value to activate each mode.
- **Dimming Value at On** [0 ... 100] %: It defines the dimming value when a “1” is received through the “[Cx][ECG x / Group x][Day/Night Mode On/Off” object for both modes, Day and Night.
- **Fade Time at On** [At once / *Fade Time 1* / *Fade Time 2* / *Fade Time 3*]
- **Dimming Value at Off** [0 ... 100] %: It defines the dimming value when a “0” is received through the “[Cx][ECG x / Group x][Day/Night Mode On/Off” object for both modes, Day and Night.
- **Fade Time at Off** [At once / *Fade Time 1* / *Fade Time 2* / *Fade Time 3*]

2.2.4.4.4 Timers

- **Timers** [enabled / disabled]: It enables the configuration of a **Simple Timer** and a **Flashing** in the dimming point, they can be used in a separated way.
 - The **Simple Timer** consist of a dimming point (optionally delayed) switch-on after receiving the trigger object and the switch-off after a parameterised value or after receiving an object (optionally with a delay).
 - The **Flashing** consist of a switching on and off the dimming point in a undefined way or during a number of repetitions, once an object is received.

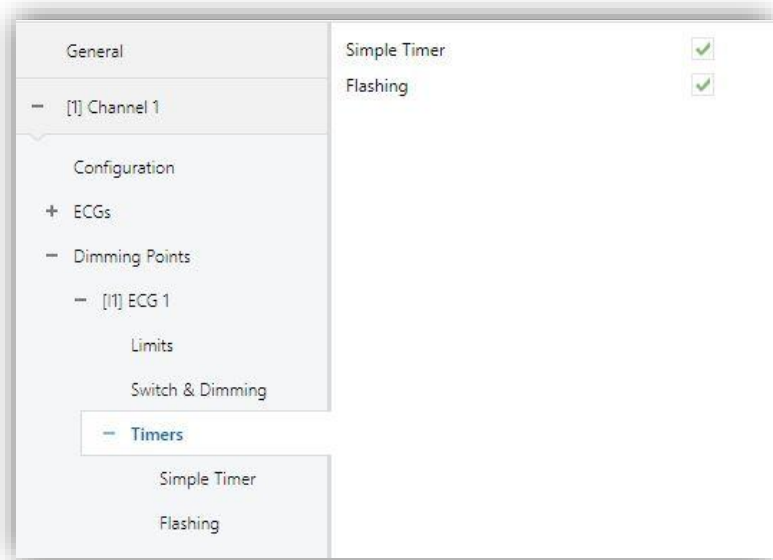

Figure 35. Timers

- **Simple Timer** *[enabled / disabled]*: If enabled, it activates a tab on the right part with the following options:

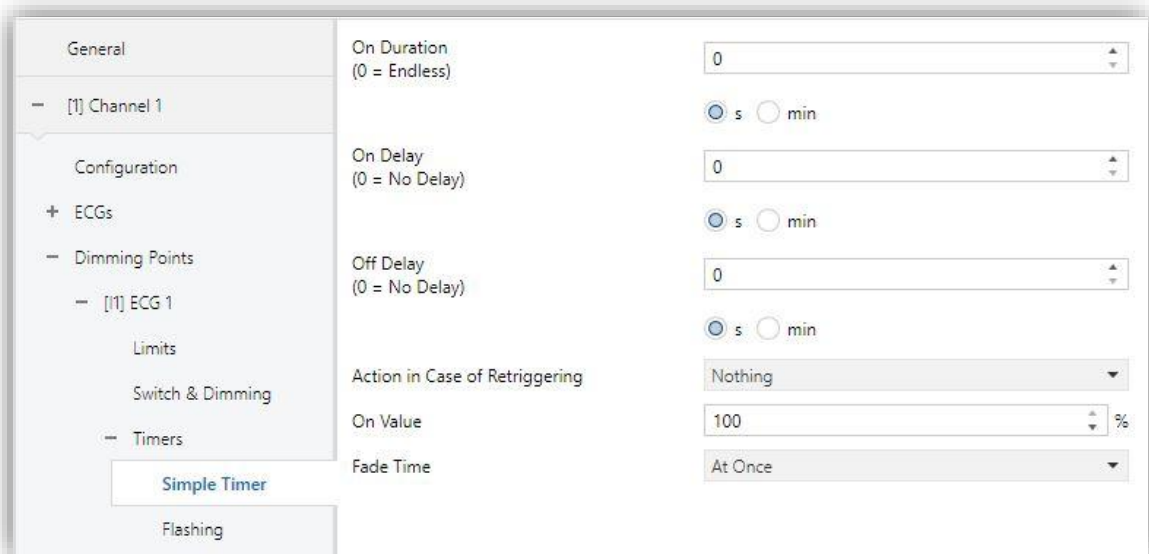

Figure 36. Simple Timer

This functionality activates the “[Cx][ECG x / Group x][Simple Timer” object, to activate or to stop the timer. The parameters are:

- **On Duration (0 = Endless)** *[0 ... 255] [s / min]*: It is the time that the dimming point will be switched-on before deactivating automatically. If “0” is selected, the automatic deactivation will not be done.

- **On Delay (0 = No Delay)** [0 ... 255] [s / min]: It is the time from activation object reception to the dimming point switching-on.
- **Off Delay (0 = No Delay)** [0 ... 255] [s / min]: It is the time from deactivation object reception to the dimming point switching-off.
- **Action in Case of Retriggering** [Nothing / Restart / Multiply]: It is the action to be done in case of receiving more than once the activation object.
 - **Nothing**: No action will be done.
 - **Restart**: The part being executed (on delay, on duration or off delay) will restart its timer.
 - **Multiply**: The part being executed will multiply by “n” its timer, where “n” is the number of times the object is received (up to five times).
- **On Value** [0 ... 100] %: It is the dimming value on the switching-on.
- **Fade Time** [At Once / Fade Time 1 / Fade Time 2 / Fade Time 3]

The **Flashing** functionality can be configured by means of the following parameters:

- **Flashing** [enabled / disabled]: If enabled, it activates a tab on the right part with the following options:

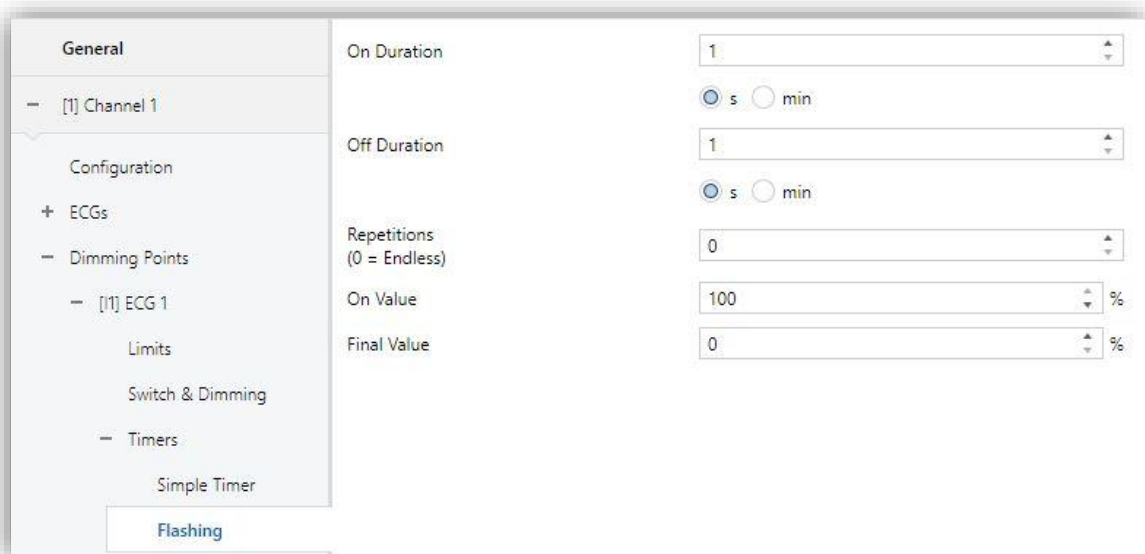

Figure 37. Flashing

This functionality activates the “[Cx][ECG x / Group x][Flashing” object, to activate or to stop the flashing. The parameters are:

- **On Duration** [1 ... 255] [s / min]: It is the duration of the “On” period.
- **Off Duration** [1 ... 255] [s / min]: It is the duration of the “Off” period.
- **Repetitions (0 = Endless)** [0 ... 100]: It is the number of repetitions of the sequence. If “0” is selected, the flashing will be repeated up to receiving a “0” value through the flashing object.
- **On Value** [0 ... 100] %: It is the dimming value during the “On” period.
- **Final Value** [0 ... 100] %: It is the dimming value after the last flashing or after receiving a “0” value through the flashing object.

2.2.4.4.5 Lock

- **Lock** [enabled / disabled]: If enabled, it activates a binary object (“**[Cx][ECG x / Group x][Lock**”) to make possible to locking or unlocking the dimming point. If the dimming point is locked, regulation orders will be ignored.



Figure 38. Lock

- **Lock Object Polarity** [0 = Unlock, 1 = Lock / 0 = Lock, 1 = Unlock]: It defines the meaning of the values received from the lock object.
- **Behaviour on Locking** [No change / Off / On / Defined Value]: It defines the action to be done on receiving the lock order. If “Defined Value” is selected, parameter **Dimming Value** [0 ... 100] [%] is shown.
- **Behaviour on Unlocking** [No change / Off / On / Defined Value / Previous Status]: It defines the action to be done on receiving the unlock order. The options are like those of Lock, adding “Previous Status” (it recovers the status before entering the lock)

2.2.4.4.6 Alarm

- **Alarm** [*enabled* / *disabled*]: This function allows to define an action of **alarm** in the dimming point that will be executed on receiving a trigger through the object “[Cx][ECG x / Group x][] Alarm”. The alarm action can define actions on activation and deactivation. When it is enabled, a new tab is shown with the following dialog:

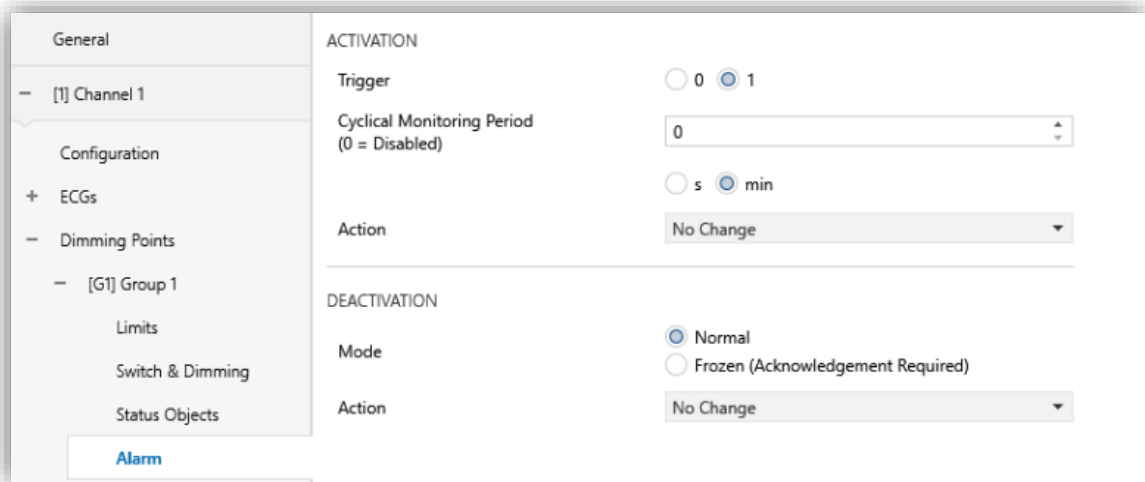

Figure 39. Alarm

The parameters of alarm **activation** are:

- **Trigger** [*0* / *1*]: It defines which value received from the “[Cx][ECG x / Group x][] Alarm” object will activate the alarm.
- **Cyclical Monitoring Period (0 = Disabled)** [*0 ... 1440*] [*s* / *min*]: It defines the maximum period of time without receiving a “non-alarm” value through the alarm object before activating automatically the alarm. If “0” is selected, the cyclical monitoring is disabled.
- **Action** [*No change* / *Off* / *On* / *Defined Value*]: It defines the action to be done on activating the alarm. If “Defined Value” is selected, parameter **Dimming Value** [*0 ... 100*] % is shown to define the dimming value during the alarm.

The parameters of alarm **deactivation** are:

- **Mode** [*Normal* / *Frozen (Acknowledgment Required)*]: It selects the deactivation mechanism. With second option, the “[Cx][ECG x / Group x][] Unfreeze Alarm”

object, to unfreeze the alarm sending a “1” do deactivate it once the alarm trigger has the “no alarm” value.

- **Action** [No change / Off / On / Defined Value / Previous Status]: It defines the action to be done on deactivating the alarm. If “Defined Value” is selected, parameter **Dimming Value** [0 ... 100] % is shown to define the dimming value after the alarm deactivation.

2.2.4.4.7 Custom Initialisation

- **Custom Initialisation** [enabled / disabled]: This function allows to define the initial status of the dimming point (before receiving any regulating order). It is considered initialization a download, a restart or the recovering after a bus failure.

Note: *This functionality is applied uniquely for each dimming point, so that when ballasts are shared in several dimming points, the last customised initialisation sent will be applied.*

When it is enabled, a new tab is shown with the following dialog:

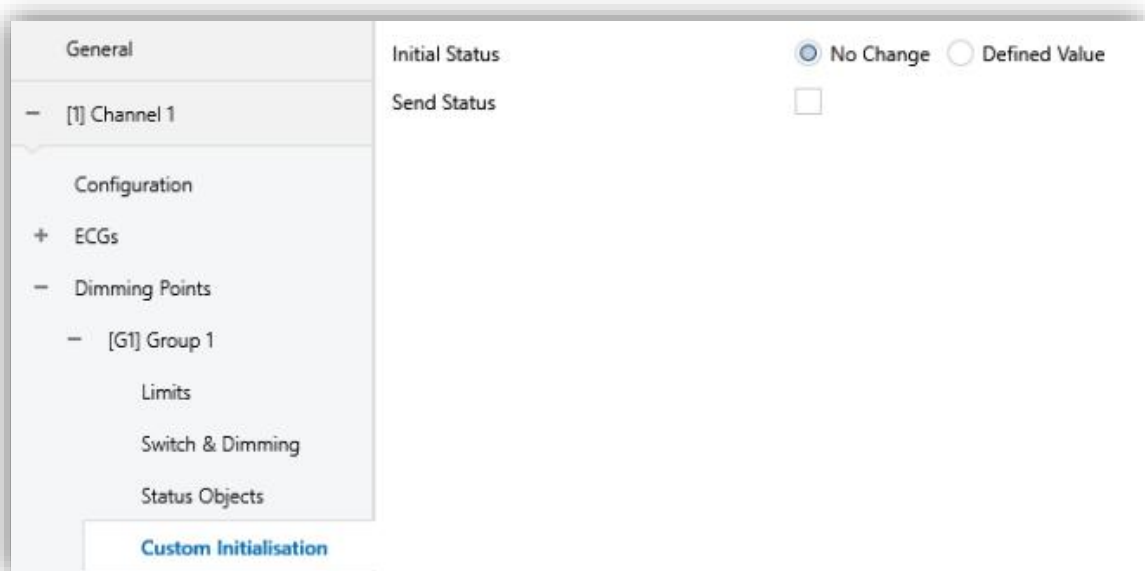

Figure 40. Custom Initialisation

- **Initial Status** [No Change / Defined Status]: It defines the initial state after an initialisation:
 - **No change:** After recovering the bus (or reset), the status of the dimming point is that previous to the bus failure. In case of download, it has no meaning, dimming point will initialise switched-off.

- **Defined Value:** The dimming point will start with the value defined by the parameter **Dimming Value** [0 ... 100] %.
- **Send Status** [enabled / disabled]: If enabled, dimming point status objects will be sent on start (it requires that status objects will be enabled). (See section 2.2.4.4). When it is enabled, a parameter is activated:
 - **Delay** [0 ... 255] s: It defines the delay of the sending.

2.2.4.4.8 Modes

- **Modes** [enabled / disabled]: This function allows to enable two modes on the dimming point parameterisation:

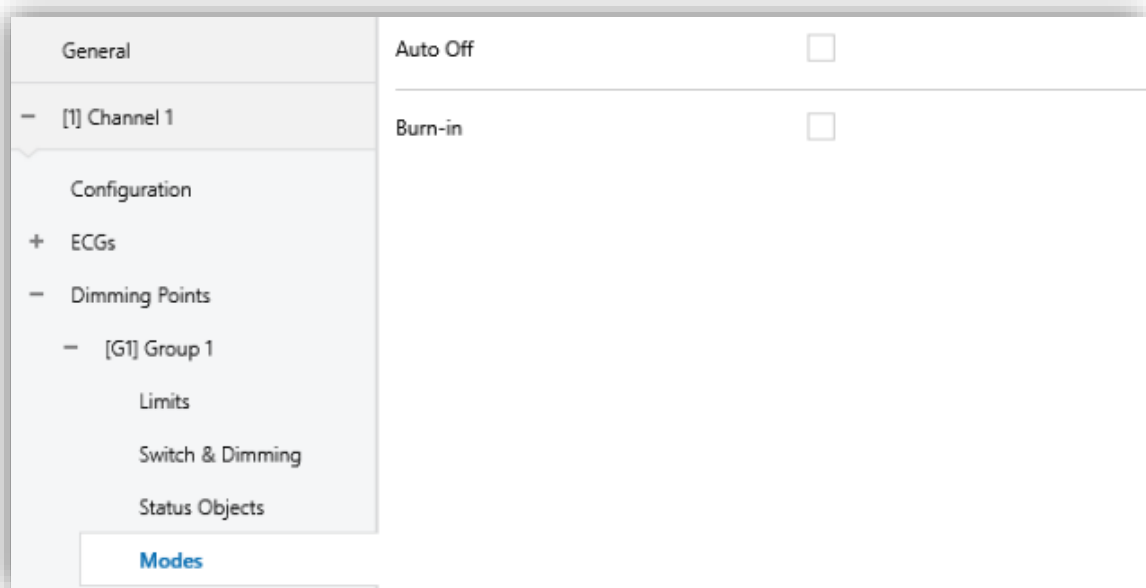

Figure 41. Modes

- **Auto off** [enabled / disabled]: The Auto Off mode switches off the dimming point when its dimming value remains during a defined time below a defined dimming value. Once the functionality **Auto Off** is enabled, following parameters can be configured:

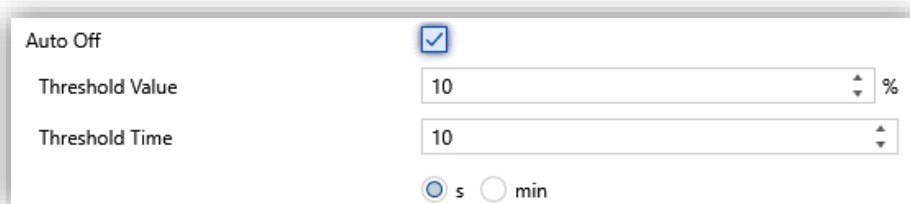

Figure 42. Auto Off

- **Threshold Value** [0 ... 10 ... 100] %: It defines the dimming value below which Auto Off can be executed if the dimming point remains under it.
- **Threshold Time** [1... 10 ... 255] [s / min]: It defines the time to switch off the dimming point if it has remained dimmed under the threshold value.
- **Burn-in** [enabled / disabled]: This functionality prevents gas lamps from being dimmed during its first hours of working when they are brand new to improve its lifetime. The duration of the burn-in process must be specified by the lamps manufacturer. Once the burn-in time is expired, the ballast can be regulated in a normal way.

This functionality is controlled by the object “[Cx][ECG x / Group x][] **Burn-in Mode**” and the status is reported by object “[Cx][ECG x / Group x][] **Burn-in Mode (Status)**”. The burn-in time can be modified with the object “[Cx][ECG x / Group x][] **Burn-in Mode Time**”.

Note: *This functionality is useful only with gas lamp facilities, to make an initial start-up that increases the lifetime. Thus, it is only available for “Normal” type dimming points. (See section 2.2.4.1)*

Once the functionality **Burn-in** is enabled, following parameters can be configured:

The screenshot shows a configuration window for 'Burn-in'. At the top, the 'Burn-in' checkbox is checked with a blue checkmark. Below it, the 'Burn-in Time' is set to '100' in a text input field with a dropdown arrow on the right and a unit 'h' to its right. Underneath, there are two radio buttons for 'Burn-in Initial Value': 'Keep Value' (which is selected) and 'Defined Value'. At the bottom of the window, there is a light blue information bar with an 'i' icon and the text 'Burn-in mode is only useful in gas lamps'.

Figure 43. Burn-in

- **Burn-in Time** [1... 100 ... 255] h: It defines the time to be active.
- **Burn-in Initial Value** [Keep Value / Defined Value]: It defines the initial value of the timer after download. If “Keep Value” is selected, the remaining burn-in time and the status after a download will be those previous to it. If “Defined Value” is selected, the parameter **Burn-in Remaining Time** [1 ... 255] h will define the necessary time to finish the burn-in mode.

2.2.4.5 DIMMING

The lower part of the dimming point parameterisation window contains functions that are applicable to the dimming point in a general way:

- **Visual Perception of Dimming** [[Lineal](#) / [Logarithmic](#)]: **KNX-DALI Interface** offers the possibility of defining the visual perception of the lamp when a dimming is done; it can be linear or logarithmic (default value). The interface sends to DALI bus the suitable values in order to achieve the final visual perception wanted by the user.
- **Curve applied by ECG** [[Standard](#) / [Linear](#)]: (only for DT6 – LED ballast type). In case of DT6, the DALI standard allows that the ballast can provide a logarithmic visual perception although they are receiving the dimming values in a linear way. This parameter allows that the calculation to achieve the logarithmic perception will be done by the ballast (“Linear” value) or by KNX-DALI Interface (“Standard” value).
- **Colour Channels Curve** [[Standard](#) / [Linear](#)]: (only for DT8 – RGB/RGBW ballast type) When RGB/RGBW ballasts are used, it is possible to perceive that the colour shown by the lamp differs from that chosen through the colour components. For these cases, it is allowed to solve this problem changing the values of the components sent to the DALI bus.

3 MANUAL CONTROL AND DISPLAY

In addition to the normal operation of the device, or its control via ETS, the device can be controlled through buttons (for both cases: having a display or not). The purpose of these controls is to make easier the setup of the DALI installation, but it is not intended to be the usual way of controlling the installation.

This section describes two ways to perform this control:

3.1 MANUAL CONTROL

This section is only applicable to devices with manual control button:

- **inBOX DALI 16**

The manual control is done through the buttons on the device and its associated LED.

When the manual button is pressed, all the dimming points in the channel are switched, i.e. if all of them are switched-on they will switch-off, or they will switch-on in all other cases. This action is similar to the sending of the control object On/Off (concerning the fade times and priorities). Status objects of these dimming points will be sent to KNX bus.

The Status LED will indicate the status of the dimming points, i.e., if any of them is switched-on the LED will be switched-on. On the contrary, if all the dimming points are switched-off, the LED will remain off.

Note: *To be able the use of the manual control, it is necessary to have done a download with the correct parameterization, having enabled the existing dimming points.*

3.2 DISPLAY

This section is only applicable to devices with display:

- **DALI BOX Interface 64 X2**
- **DALI BOX Interface 64 v3**

The device has a screen with 128x64 pixels and 6 buttons that allow to manage the display menus.

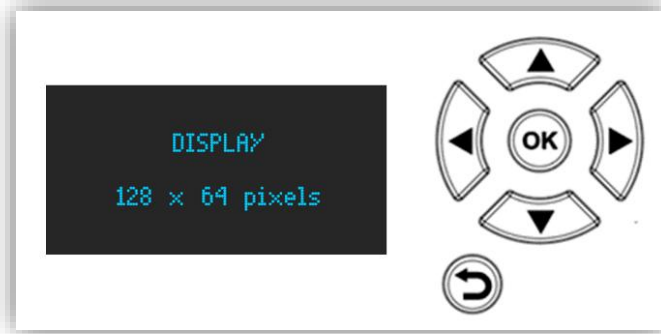

Figure 44. Display and buttons

The Display is on the left part of the device and, on the right, the buttons have a selector (▼►▲◀) to scroll in the four directions and a button (OK) in the centre to confirm the chosen option. In the lower part, there is another button to cancel the action (↶).

In the normal state, the display is off. It will be activated on pressing any button and, after one minute of inactivity, it will switch off.

Note: *KNX-DALI Interface* allows to represent in the display the Latin, extended Latin, Cyrillic alphabets and some special characters (€ ¢ £ ° ° ñ).

3.2.1 CHANNEL SELECTOR

This menu is available in devices that have the possibility to controlling more than one channel. Thus, it is the first menu to be shown in these devices.

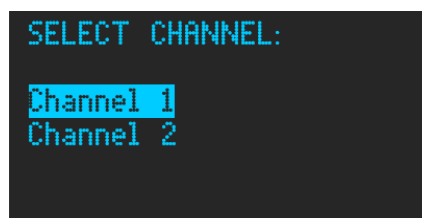

Figure 45. Channel selection menu

The desired channel can be selected using the arrow buttons: ▼ or ► to down the selector and ▲ or ◀ to up the selector.

Note: *Devices with only one channel will show directly main menu.*

3.2.2 MAIN MENU

When a channel is chosen, this menu allows to choose some options related to the channel.

This menu is represented with a enumerated list of configuration options. Due to screen limitations it es not possible to show all the options, therefore it is necessary to make a vertical scroll.

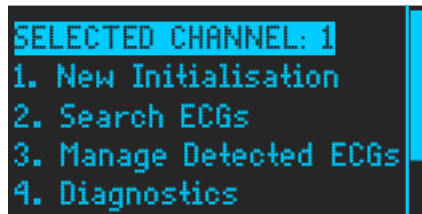

Figure 46. Main menu (1-4)

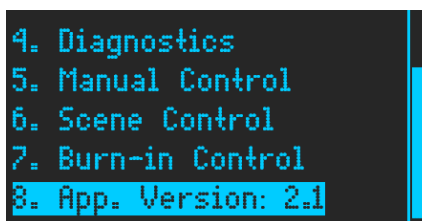

Figure 47. Main menu (4-8)

The list is formed by the following options:

- ***New Initialisation***
- ***Search ECGs***
- ***Manage Detected ECGs***
- ***Diagnostics***
- ***Manual Control***
- ***Scene Control***
- ***Burn-in Control***
- ***Application Version: X.X***

The different options available in this menu are detailed below. For security reasons, the user is allowed to password protect **the first three sub-menus**:

3.2.2.1 PASSWORD

Set a 4-digit password that will prompt the user to manipulate the Display, to prevent unwanted changes.

The first time you try to log in, you will be prompted for your password via the following screen:

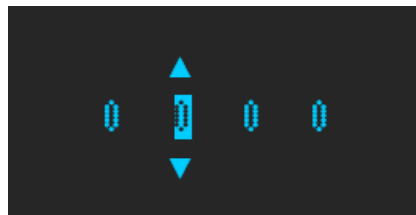

Figure 48. Display password

The display will show, inverting the colours, the selected number, and ▲ and ▼ can be used to increase or decrease its value, and ► and ◀ can be used to scroll between the 4 numbers. Pressing the **OK** button validates the number displayed on the screen. Access will be granted if it is correct, or the message “*Password is not Correct*” will be displayed if it is not.

Pressing the **Back** button will return to the main menu and cancel the action.

After the screen times out, it will turn off, and will ask for the password again if you wish to re-enter any of these sub-menus.

3.2.2.2 NEW INITIALISATION

This menu allows to reset all the ECGs connected to the DALI channel (these ballasts can be associated with a dimming point or not). After the reset, they will lose the individual address and they will get the default configuration. Once the **OK** button is pressed, this menu is shown:

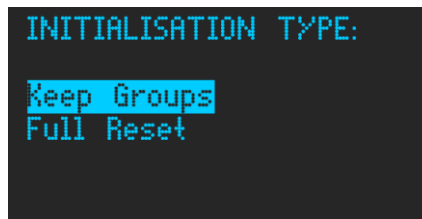

Figure 49. New Initialisation options

Two types of new initialisation can be done:

Keep Groups: When this option is selected pressing **OK** button a resetting ballasts process will start. At the beginning of the process, groups associated with each individual address is read. Then Reset is done and new addresses are assigned to each ballast. To each individual address is assigned the previously saved associated groups.

Full Reset: When this option is selected pressing **OK** button a Reset is done and new addresses are assigned to each ballast.

When the button **OK** is pressed a confirmation message is displayed:



Figure 50. New Initialisation confirmation

When it is confirmed, a waiting message (“Detection in progress Please wait...”) is displayed while the ballast configuration progress is performed. This message blocks all the actions to be done through the Display or the DCA. Once all the ballasts are detected, main menu will be displayed.

The waiting message has this appearance:

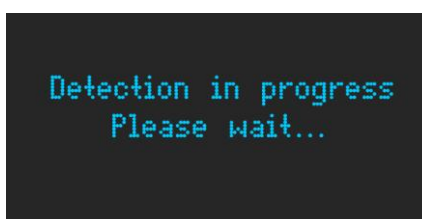

Figure 51. Configuration waiting message

When this process finishes, all the ballasts have a new individual address.

Note: It is recommended that will process will be done after ETS installation parameterization.

3.2.2.3 SEARCH ECGS

This menu allows to find the ballasts connected to the channel. There are two ways to search them:

- **Only Addressed:** With this option, only ballasts with a previously assigned address will be found.
- **All ECGs:** With this option, all ballasts (both, with individual address and without it) connected to the channel will be found.

When one of these options is selected with the **OK** button, following button is displayed:

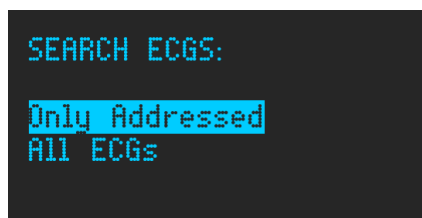

Figure 52. Search ECGs options

During the searching process, the device will block any other actions of the display or DCA, like in New Initialisation process, showing a waiting message (see Figure 51).

During this process, it is possible to find two ballasts having the same individual addresses, resulting in a collision response. In this case, a warning message is shown allowing to reassign these addresses ("READDRESS") or to ignore ("IGNORE") the problem.

This message has the appearance:

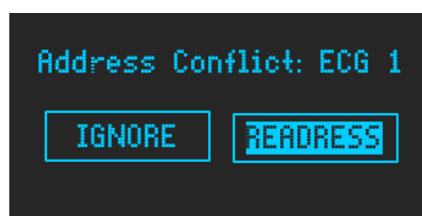

Figure 53. Ballasts address conflict

Desired option can be chosen using the arrows (◀ and ▶) and pressing **OK**.

Note: The “Ignore” option must not be used to use several ECGs with the same address. This option is foreseen to continue the search without making a readdress process to the ballast.

3.2.2.4 MANAGE DETECTED ECGS

Once an individual address has been assigned to all the ballasts, this menu allows to modify the address manually, to get the installation configuration. They can also be associated with one or more groups:

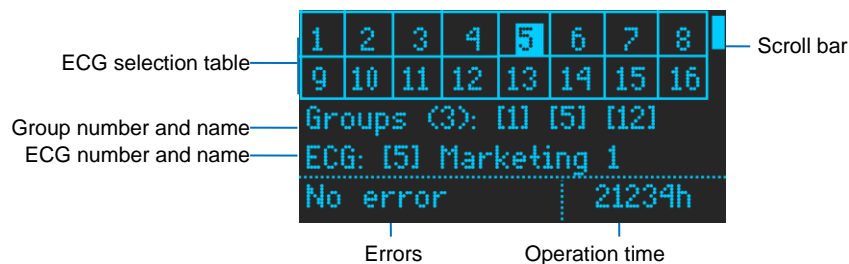

Figure 54. Detected ballasts management

Once this menu is selected pressing **OK**, with the arrow buttons (▲, ▼, ◀ and ▶) the selected ballast (displayed with flashing lighter shading) can be changed.

The selected ballast will be in “Ballast location mode”, that is, the ballast will be flashing switching-on and off each second.

The table can include up to 64 ballasts, placed on 8 rows. A scroll bar will be shown at the right part to represent the current row.

When selecting each ballast, it will be displayed in the lower half of the ballast, if the ballast has one or more associated groups, and the name that has been assigned to the ballast in ETS. On the left lower corner possible errors are shown (Presence error, Lamp error or converter error). On the right lower corner, the operation time is shown.

- **ECG Errors:** Several types of ballast errors can be shown:
 - **Presence:** This error is produced when a previously recognized ballast is disconnected:

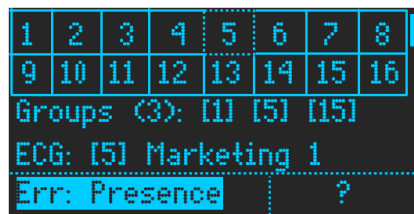

Figure 55. Presence Error selected

In this case, operation time of the ballast is not shown because, as the ballast is not connected, it is unknown. In case of having a ballast with presence error this error can be selected (light shading). Thus, this error can be removed deleting the ballast. While the error is selected, if **OK** button is pressed, a confirmation dialog allows to delete the ECG.

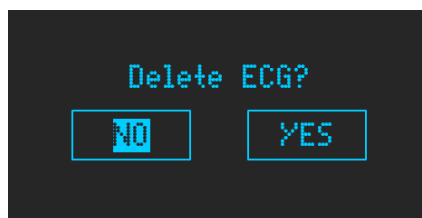

Figure 56. Delete ECG confirmation

- **ECG Failure:** It represents an error reported by the ballast.

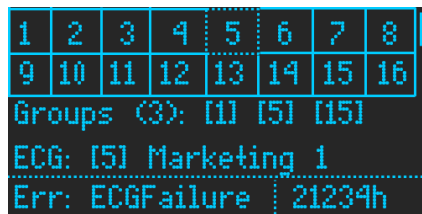

Figure 57. ECG Failure Error

- **Lamp Failure:** It represents an error in the lamp reported by the ballast.

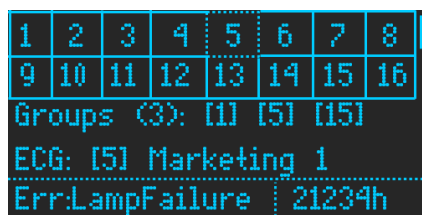

Figure 58. Lamp Failure Error

Note: It is possible that Lamp Failure and ECG Failure are reported simultaneously by the ballast. In this case “Err: ECG & Lamp” will be shown.

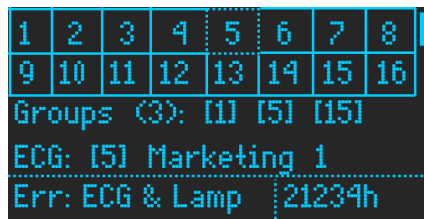

Figure 59. Lamp and ECG Failure Error

When one of the ballasts is selected by pressing the **OK** button on the selected ballast, the up or down actions (**▲** and **▼**) with the selector switch are possible:

- **Groups:** When “Groups ()” is selected, pressing OK, the ballast may be associated to one or more groups by moving the arrows from left to right (**◀** and **▶**). The groups assigned to the ballast is shown underlined:

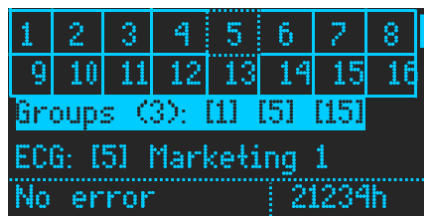

Figure 60. Group selection

When the desired groups have been marked, they are selected by confirming with a long press on the **OK** button:

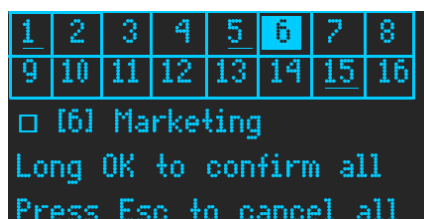

Figure 61. Group assigned to the ballast

- **ECG:** When “ECG” is selected, pressing **OK**, it is possible to change the individual address of the ballast using the left and right arrows (**◀** and **▶**). If the address is assigned to other ballast, their address (and configuration) will be swapped.

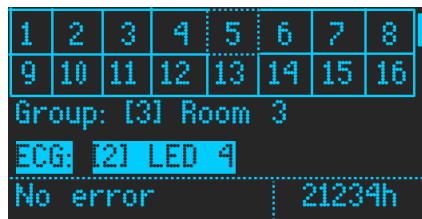

Figure 62. ECG Address modification

Note: It must be considered that **KNX-DALI Interface** shows ballast numeration in the range 1 to 64. Internally, DALI bus works with numeration range 0 to 63, i.e. subtracting a unit from the value shown in the display.

- **Operation Time:** It is allowed to reset the operation time counter. The number of hours must be selected using the arrow buttons (▼ and ▲) until it is light shaded:

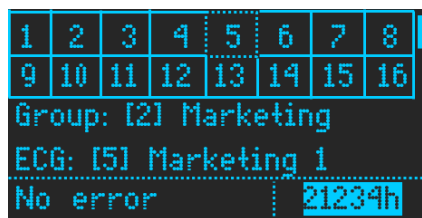

Figure 63. Operation Time

When it is selected, pressing **OK** a confirmation dialog is shown:



Figure 64. Operation Time reset confirmation

If option “Yes” is selected, the Operation Time will be set to 0 hours.

3.2.2.5 DIAGNOSTICS

Show the errors that are currently present on the DALI bus. When selecting this submenu, the following summary will be displayed:

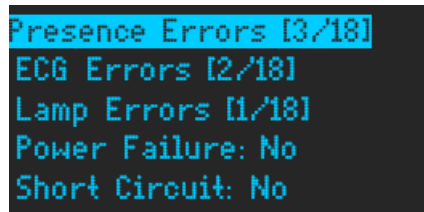

Figure 65. Diagnostics submenu

This submenu shows whether the DALI bus is powered, or has a power failure, as well as whether the wiring is short-circuited.

By selecting one of the first three errors, a table (4 rows and 8 columns) is displayed, which shows the address of the ballast that contains one of the errors. By scrolling with the arrows, the ballasts will be displayed in two tables of up to 32 ballasts:

1	2			5			
	10						
17							
						31	

Figure 66. Diagnostic table per ballasts

3.2.2.6 MANUAL CONTROL

In order to check the correct working of the installation, manual control is possible for all configured dimming points (individual, groups and broadcast). When his option is selected and **OK** button is pressed, this menu is shown:

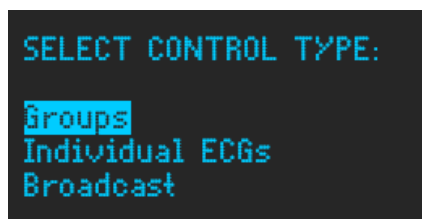

Figure 67. Manual Control menu

An option (Groups, Individual ECGs and Broadcast) can be selected using the arrows (▼ and ▲) and pressing **OK**. A table containing the chosen dimming points is shown:

1	2		4	5	6	7	8
	10	11					
Group: [6] Hall							

Figure 68. Dimming Point table

The desired dimming point can be selected (using the arrows: ◀, ▶, ▼ and ▲) and pressing **OK**. Once a dimming point is chosen, in the lower part of the display actions are to be done with the buttons are shown.



Figure 69. Manual control actions

The possible actions of manual control are:

- ▶: It provokes an On command.
- ◀: It provokes an Off command.
- ▲: It provokes an increasing relative regulation.
- ▼: It provokes a decreasing relative regulation.

These actions are equivalent to the sending of the KNX control objects; therefore, status objects will be sent.

Note: *Figures in this section belong to a group dimming point. In case of individual dimming point, the images should be similar, showing “ECG” instead of “Group”.*

In case of selecting Broadcast control, the functionality is the same, but the table will not appear, and no selection will be necessary, as there would only be one option.

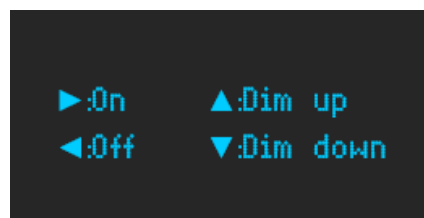

Figure 70. Broadcast manual control

3.2.2.7 SCENE CONTROL

When this option is selected and **OK** button is pressed, a table showing the configured scenes is displayed in an 8-row table (with scroll bar):

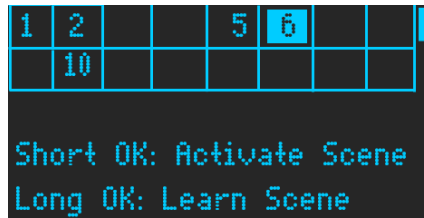

Figure 71. Manual control dialog

The selected scene (light shaded) can be modified using the arrow buttons (▼, ▲, ◀ and ▶).

The scene can be activated pressing shortly the **OK** button. If a long press is done, the scene will be saved (see section 2.2.1.1). Once a scene is sent or saved, a message will be shown indicating the action done.

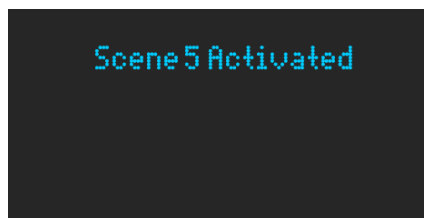

Figure 72. Scene control message

When the scene is activated, the status objects will be sent to the KNX bus.

Note: *The figure refers to a scene activation. In case of save a scene the message shows “Saved” instead of “Activated”.*

3.2.2.8 BURN-IN CONTROL

Burn-in control can be done from display for all configured dimming points (individual, groups or broadcast). When his option is selected and **OK** button is pressed, this menu is shown:

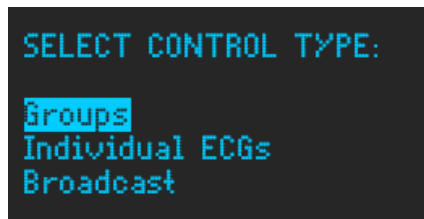

Figure 73. Burn-in type selection

When any of the options is selected (Groups or Individual ECGs) and **OK** is pressed, a table containing the configured dimming points is displayed:

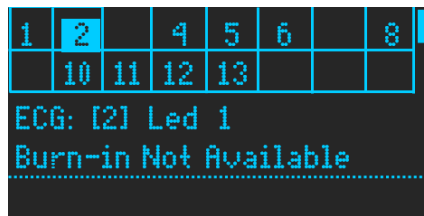

Figure 74. Burn-in not available

The previous figure shows the case of a dimming point which Burn-in mode is not enabled. On the other hand, if Burn-in mode is enabled for the selected dimming point but it is inactive, when it is selected will be shown this option:

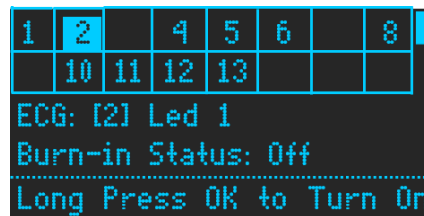

Figure 75. Burn-in inactive

If **OK** button is long pressed, the burn-in status will be modified as showed:

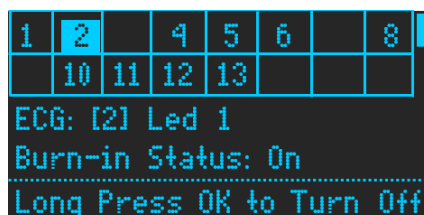

Figure 76. Burn-in active

3.2.2.9 APLICATION VERSION: X.X

The option “App Version” does not have any specific menu. It indicates de current program version downloaded in the device.

ANNEX I. COMMUNICATION OBJECTS

- “Functional range” shows the values that, with independence of any other values permitted by the bus according to the object size, may be of any use or have a particular meaning because of the specifications or restrictions from both the KNX standard or the application program itself.

Number	Size	I/O	Flags	Data type (DPT)	Functional Range	Name	Function
1	1 Bit	O	CR-T-	DPT_Trigger	0/1	[Heartbeat] Object to Send '1'	Sending of '1' Periodically
2	1 Bit	O	CR-T-	DPT_Trigger	0/1	[Heartbeat] Device Recovery	Send 0
3	1 Bit	O	CR-T-	DPT_Trigger	0/1	[Heartbeat] Device Recovery	Send 1
4	1 Bit	O	CR-T-	DPT_Alarm	0/1	Error: DALI Power Supply	0 = No Error; 1 = DALI Power Supply Failure
5	1 Bit	I	C-W--	DPT_Enable	0/1	Manual Control Lock	0 = Unlock; 1 = Lock
	1 Bit	I	C-W--	DPT_Enable	0/1	Manual Control Lock	0 = Lock; 1 = Unlock
6, 2555	1 Byte	I	C-W--	1.xxx	0/1	[Cx] Fade Time 1	DALI Fade Time
7, 2556	1 Byte	I	C-W--	1.xxx	0/1	[Cx] Fade Time 2	DALI Fade Time
8, 2557	1 Byte	I	C-W--	1.xxx	0/1	[Cx] Fade Time 3	DALI Fade Time
9, 2558	1 Byte	I	C-W--	DPT_SceneControl	0-63; 128-191	[Cx] Scene Control	0 - 63 (Run Scene 1 - 64); 128 - 191 (Save Scene 1 - 64)
10, 2559	1 Byte	I	C-W--	DPT_DALI_Efect_1_Byte		[Cx] Sequence Control	Sequence Number + Start/Stop
11, 2560	1 Byte	I	C-W--	DPT_SceneNumber	0 - 63	[Cx] Sequence Launcher	Start Sequence Number
12, 2561	1 Bit	I	C-W--	DPT_Trigger	0/1	[Cx] Stop Sequences	Stop All Sequences
13, 2562	1 Bit	O	CR-T-	DPT_Alarm	0/1	[Cx] Error: Short Circuit	0 = No Error; 1 = Short Circuit Failure
14, 2563	1 Bit	I/O	CRWT-	DPT_Alarm	0/1	[Cx] Error: Presence	0 = No Error; 1 = Presence Error
15, 2564	1 Bit	O	CR-T-	DPT_Alarm	0/1	[Cx] Error: ECG	0 = No Error; 1 = ECG Error
16, 2565	1 Bit	O	CR-T-	DPT_Alarm	0/1	[Cx] Error: Lamp	0 = No Error; 1 = Lamp Error
17, 2566	1 Byte	O	CR-T-	DPT_DALI_Diagnostic		[Cx] ECG Diagnostic	ECG Diagnostic
18, 2567	2 Bytes	I	C-WT-	DPT_DALI_Control_Gear_Diagnostics		[Cx] ECG and Group Diagnostic	ECG and Group Diagnostic
19, 20, 21, 22, 23, 24, 25, 26, 27, 28, 29, 30, 31, 32, 33, 34, 2568, 2569, 2570, 2571, 2572, 2573, 2574, 2575, 2576, 2577, 2578, 2579, 2580, 2581, 2582, 2583	1 Bit	O	CR-T-	DPT_Switch	0/1	[Cx] Standby x (Status)	0 = Standby Off; 1 = Standby On
	1 Bit	O	CR-T-	DPT_Switch	0/1	[Cx] Standby x (Status)	0 = Standby On; 1 = Standby Off

35, 44, 53, 62, 71, 80, 89, 98, 107, 116, 125, 134, 143, 152, 161, 170, 179, 188, 197, 206, 215, 224, 233, 242, 251, 260, 269, 278, 287, 296, 305, 314, 323, 332, 341, 350, 359, 368, 377, 386, 395, 404, 413, 422, 431, 440, 449, 458, 467, 476, 485, 494, 503, 512, 521, 530, 539, 548, 557, 566, 575, 584, 593, 602, 2584, 2593, 2602, 2611, 2620, 2629, 2638, 2647, 2656, 2665, 2674, 2683, 2692, 2701, 2710, 2719, 2728, 2737, 2746, 2755, 2764, 2773, 2782, 2791, 2800, 2809, 2818, 2827, 2836, 2845, 2854, 2863, 2872, 2881, 2890, 2899, 2908, 2917, 2926, 2935, 2944, 2953, 2962, 2971, 2980, 2989, 2998, 3007, 3016, 3025, 3034, 3043, 3052, 3061, 3070, 3079, 3088, 3097, 3106, 3115, 3124, 3133, 3142, 3151	1 Bit	I/O	CRWT-	DPT_Alarm	0/1	[Cx] Presence Error	0 = No Error; 1 = Presence Error
36, 45, 54, 63, 72, 81, 90, 99, 108, 117, 126, 135, 144, 153, 162, 171, 180, 189, 198, 207, 216, 225, 234, 243, 252, 261, 270, 279, 288, 297, 306, 315, 324, 333, 342, 351, 360, 369, 378, 387, 396, 405, 414, 423, 432, 441, 450, 459, 468, 477, 486, 495, 504, 513, 522, 531, 540, 549, 558, 567, 576, 585, 594, 603, 2585, 2594, 2603, 2612, 2621, 2630, 2639, 2648, 2657, 2666, 2675, 2684, 2693, 2702, 2711, 2720, 2729, 2738, 2747, 2756, 2765, 2774, 2783, 2792, 2801, 2810, 2819, 2828, 2837, 2846, 2855, 2864, 2873, 2882, 2891, 2900, 2909, 2918, 2927, 2936, 2945, 2954, 2963, 2972, 2981, 2990, 2999, 3008, 3017, 3026, 3035, 3044, 3053, 3062, 3071, 3080, 3089, 3098, 3107, 3116, 3125, 3134, 3143, 3152	1 Bit	O	CR-T-	DPT_Alarm	0/1	[Cx] ECG Error	0 = No Error; 1 = ECG Error
37, 46, 55, 64, 73, 82, 91, 100, 109, 118, 127, 136, 145, 154, 163, 172, 181, 190, 199, 208, 217, 226, 235, 244, 253, 262, 271, 280, 289, 298, 307, 316, 325, 334, 343, 352, 361, 370, 379, 388, 397, 406, 415, 424, 433, 442, 451, 460, 469, 478, 487, 496, 505, 514, 523, 532, 541, 550, 559, 568, 577, 586, 595, 604, 2586, 2595, 2604, 2613, 2622, 2631, 2640,	1 Bit	O	CR-T-	DPT_Alarm	0/1	[Cx] Lamp Error	0 = No Error; 1 = Lamp Error

2649, 2658, 2667, 2676, 2685, 2694, 2703, 2712, 2721, 2730, 2739, 2748, 2757, 2766, 2775, 2784, 2793, 2802, 2811, 2820, 2829, 2838, 2847, 2856, 2865, 2874, 2883, 2892, 2901, 2910, 2919, 2928, 2937, 2946, 2955, 2964, 2973, 2982, 2991, 3000, 3009, 3018, 3027, 3036, 3045, 3054, 3063, 3072, 3081, 3090, 3099, 3108, 3117, 3126, 3135, 3144, 3153							
38, 47, 56, 65, 74, 83, 92, 101, 110, 119, 128, 137, 146, 155, 164, 173, 182, 191, 200, 209, 218, 227, 236, 245, 254, 263, 272, 281, 290, 299, 308, 317, 326, 335, 344, 353, 362, 371, 380, 389, 398, 407, 416, 425, 434, 443, 452, 461, 470, 479, 488, 497, 506, 515, 524, 533, 542, 551, 560, 569, 578, 587, 596, 605, 2587, 2596, 2605, 2614, 2623, 2632, 2641, 2650, 2659, 2668, 2677, 2686, 2695, 2704, 2713, 2722, 2731, 2740, 2749, 2758, 2767, 2776, 2785, 2794, 2803, 2812, 2821, 2830, 2839, 2848, 2857, 2866, 2875, 2884, 2893, 2902, 2911, 2920, 2929, 2938, 2947, 2956, 2965, 2974, 2983, 2992, 3001, 3010, 3019, 3028, 3037, 3046, 3055, 3064, 3073, 3082, 3091, 3100, 3109, 3118, 3127, 3136, 3145, 3154	1 Bit	O	CR-T-	DPT_Alarm	0/1	[Cx] Operation Time Alarm	0 = No Alarm; 1 = Alarm
39, 48, 57, 66, 75, 84, 93, 102, 111, 120, 129, 138, 147, 156, 165, 174, 183, 192, 201, 210, 219, 228, 237, 246, 255, 264, 273, 282, 291, 300, 309, 318, 327, 336, 345, 354, 363, 372, 381, 390, 399, 408, 417, 426, 435, 444, 453, 462, 471, 480, 489, 498, 507, 516, 525, 534, 543, 552, 561, 570, 579, 588, 597, 606, 2588, 2597, 2606, 2615, 2624, 2633, 2642, 2651, 2660, 2669, 2678, 2687, 2696, 2705, 2714, 2723, 2732, 2741, 2750, 2759, 2768, 2777, 2786, 2795, 2804, 2813, 2822, 2831, 2840, 2849, 2858, 2867, 2876, 2885, 2894, 2903, 2912, 2921, 2930, 2939, 2948, 2957, 2966, 2975, 2984, 2993, 3002, 3011, 3020, 3029, 3038, 3047, 3056, 3065, 3074, 3083, 3092, 3101, 3110, 3119, 3128, 3137, 3146, 3155	4 Bytes	I/O	CRWT-	DPT_LongDeltaTimeSec	-2147483648 - 2147483647	[Cx] Operation Time	Time in Seconds
39, 48, 57, 66, 75, 84, 93, 102, 111, 120, 129, 138, 147, 156, 165, 174, 183, 192, 201, 210, 219, 228, 237, 246, 255, 264, 273, 282, 291, 300, 309, 318, 327, 336, 345, 354, 363, 372, 381, 390, 399, 408, 417, 426, 435, 444, 453, 462, 471, 480, 489, 498, 507, 516, 525, 534, 543, 552, 561, 570, 579, 588, 597, 606, 2588, 2597, 2606, 2615, 2624, 2633, 2642, 2651, 2660, 2669, 2678, 2687, 2696, 2705, 2714, 2723, 2732, 2741, 2750, 2759, 2768, 2777, 2786, 2795, 2804, 2813, 2822, 2831, 2840, 2849, 2858, 2867, 2876, 2885, 2894, 2903, 2912, 2921, 2930, 2939, 2948, 2957, 2966, 2975, 2984, 2993, 3002, 3011, 3020, 3029, 3038, 3047, 3056, 3065, 3074, 3083, 3092, 3101, 3110, 3119, 3128, 3137, 3146, 3155	4 Bytes	I/O	CRWT-	1.xxx	0/1	[Cx] Operation Time	Time in Hours

40, 49, 58, 67, 76, 85, 94, 103, 112, 121, 130, 139, 148, 157, 166, 175, 184, 193, 202, 211, 220, 229, 238, 247, 256, 265, 274, 283, 292, 301, 310, 319, 328, 337, 346, 355, 364, 373, 382, 391, 400, 409, 418, 427, 436, 445, 454, 463, 472, 481, 490, 499, 508, 517, 526, 535, 544, 553, 562, 571, 580, 589, 598, 607, 2589, 2598, 2607, 2616, 2625, 2634, 2643, 2652, 2661, 2670, 2679, 2688, 2697, 2706, 2715, 2724, 2733, 2742, 2751, 2760, 2769, 2778, 2787, 2796, 2805, 2814, 2823, 2832, 2841, 2850, 2859, 2868, 2877, 2886, 2895, 2904, 2913, 2922, 2931, 2940, 2949, 2958, 2967, 2976, 2985, 2994, 3003, 3012, 3021, 3030, 3039, 3048, 3057, 3066, 3075, 3084, 3093, 3102, 3111, 3120, 3129, 3138, 3147, 3156	1 Byte	I	C - W - -	1.xxx	0/1	[Cx] Converter Control	Control Command
41, 50, 59, 68, 77, 86, 95, 104, 113, 122, 131, 140, 149, 158, 167, 176, 185, 194, 203, 212, 221, 230, 239, 248, 257, 266, 275, 284, 293, 302, 311, 320, 329, 338, 347, 356, 365, 374, 383, 392, 401, 410, 419, 428, 437, 446, 455, 464, 473, 482, 491, 500, 509, 518, 527, 536, 545, 554, 563, 572, 581, 590, 599, 608, 2590, 2599, 2608, 2617, 2626, 2635, 2644, 2653, 2662, 2671, 2680, 2689, 2698, 2707, 2716, 2725, 2734, 2743, 2752, 2761, 2770, 2779, 2788, 2797, 2806, 2815, 2824, 2833, 2842, 2851, 2860, 2869, 2878, 2887, 2896, 2905, 2914, 2923, 2932, 2941, 2950, 2959, 2968, 2977, 2986, 2995, 3004, 3013, 3022, 3031, 3040, 3049, 3058, 3067, 3076, 3085, 3094, 3103, 3112, 3121, 3130, 3139, 3148, 3157	1 Byte	I	C - W - -	DPT_Converter_Test_Control		[Cx] Converter Test Control	Control Test Command
42, 51, 60, 69, 78, 87, 96, 105, 114, 123, 132, 141, 150, 159, 168, 177, 186, 195, 204, 213, 222, 231, 240, 249, 258, 267, 276, 285, 294, 303, 312, 321, 330, 339, 348, 357, 366, 375, 384, 393, 402, 411, 420, 429, 438, 447, 456, 465, 474, 483, 492, 501, 510, 519, 528, 537, 546, 555, 564, 573, 582, 591, 600, 609, 2591, 2600, 2609, 2618, 2627, 2636, 2645,	2 Bytes	O	C R - T -	DPT_Converter_Status		[Cx] Converter Status	Converter Status

2654, 2663, 2672, 2681, 2690, 2699, 2708, 2717, 2726, 2735, 2744, 2753, 2762, 2771, 2780, 2789, 2798, 2807, 2816, 2825, 2834, 2843, 2852, 2861, 2870, 2879, 2888, 2897, 2906, 2915, 2924, 2933, 2942, 2951, 2960, 2969, 2978, 2987, 2996, 3005, 3014, 3023, 3032, 3041, 3050, 3059, 3068, 3077, 3086, 3095, 3104, 3113, 3122, 3131, 3140, 3149, 3158							
43, 52, 61, 70, 79, 88, 97, 106, 115, 124, 133, 142, 151, 160, 169, 178, 187, 196, 205, 214, 223, 232, 241, 250, 259, 268, 277, 286, 295, 304, 313, 322, 331, 340, 349, 358, 367, 376, 385, 394, 403, 412, 421, 430, 439, 448, 457, 466, 475, 484, 493, 502, 511, 520, 529, 538, 547, 556, 565, 574, 583, 592, 601, 610, 2592, 2601, 2610, 2619, 2628, 2637, 2646, 2655, 2664, 2673, 2682, 2691, 2700, 2709, 2718, 2727, 2736, 2745, 2754, 2763, 2772, 2781, 2790, 2799, 2808, 2817, 2826, 2835, 2844, 2853, 2862, 2871, 2880, 2889, 2898, 2907, 2916, 2925, 2934, 2943, 2952, 2961, 2970, 2979, 2988, 2997, 3006, 3015, 3024, 3033, 3042, 3051, 3060, 3069, 3078, 3087, 3096, 3105, 3114, 3123, 3132, 3141, 3150, 3159	6 Bytes	O	CR-T-	DPT_DALI_converter_test_result		[Cx] Converter Test Result	Test Result
611, 635, 659, 683, 707, 731, 755, 779, 803, 827, 851, 875, 899, 923, 947, 971, 995, 1019, 1043, 1067, 1091, 1115, 1139, 1163, 1187, 1211, 1235, 1259, 1283, 1307, 1331, 1355, 1379, 1403, 1427, 1451, 1475, 1499, 1523, 1547, 1571, 1595, 1619, 1643, 1667, 1691, 1715, 1739, 1763, 1787, 1811, 1835, 1859, 1883, 1907, 1931, 1955, 1979, 2003, 2027, 2051, 2075, 2099, 2123, 2147, 2171, 2195, 2219, 2243, 2267, 2291, 2315, 2339, 2363, 2387, 2411, 2435, 2459, 2483, 2507, 2531, 3160, 3184, 3208, 3232, 3256, 3280, 3304, 3328, 3352, 3376, 3400, 3424, 3448, 3472, 3496, 3520, 3544, 3568, 3592, 3616, 3640, 3664, 3688, 3712, 3736, 3760, 3784, 3808, 3832, 3856, 3880, 3904, 3928, 3952, 3976, 4000, 4024, 4048, 4072, 4096, 4120,	1 Bit	I	C-W--	DPT_Switch	0/1	[Cx] On/Off	0 = Off; 1 = On

4144, 4168, 4192, 4216, 4240, 4264, 4288, 4312, 4336, 4360, 4384, 4408, 4432, 4456, 4480, 4504, 4528, 4552, 4576, 4600, 4624, 4648, 4672, 4696, 4720, 4744, 4768, 4792, 4816, 4840, 4864, 4888, 4912, 4936, 4960, 4984, 5008, 5032, 5056, 5080							
612, 636, 660, 684, 708, 732, 756, 780, 804, 828, 852, 876, 900, 924, 948, 972, 996, 1020, 1044, 1068, 1092, 1116, 1140, 1164, 1188, 1212, 1236, 1260, 1284, 1308, 1332, 1356, 1380, 1404, 1428, 1452, 1476, 1500, 1524, 1548, 1572, 1596, 1620, 1644, 1668, 1692, 1716, 1740, 1764, 1788, 1812, 1836, 1860, 1884, 1908, 1932, 1956, 1980, 2004, 2028, 2052, 2076, 2100, 2124, 2148, 2172, 2196, 2220, 2244, 2268, 2292, 2316, 2340, 2364, 2388, 2412, 2436, 2460, 2484, 2508, 2532, 3161, 3185, 3209, 3233, 3257, 3281, 3305, 3329, 3353, 3377, 3401, 3425, 3449, 3473, 3497, 3521, 3545, 3569, 3593, 3617, 3641, 3665, 3689, 3713, 3737, 3761, 3785, 3809, 3833, 3857, 3881, 3905, 3929, 3953, 3977, 4001, 4025, 4049, 4073, 4097, 4121, 4145, 4169, 4193, 4217, 4241, 4265, 4289, 4313, 4337, 4361, 4385, 4409, 4433, 4457, 4481, 4505, 4529, 4553, 4577, 4601, 4625, 4649, 4673, 4697, 4721, 4745, 4769, 4793, 4817, 4841, 4865, 4889, 4913, 4937, 4961, 4985, 5009, 5033, 5057, 5081	1 Bit	O	CR - T -	DPT_Switch	0/1	[Cx] On/Off (Status)	0 = Off; 1 = On
613, 637, 661, 685, 709, 733, 757, 781, 805, 829, 853, 877, 901, 925, 949, 973, 997, 1021, 1045, 1069, 1093, 1117, 1141, 1165, 1189, 1213, 1237, 1261, 1285, 1309, 1333, 1357, 1381, 1405, 1429, 1453, 1477, 1501, 1525, 1549, 1573, 1597, 1621, 1645, 1669, 1693, 1717, 1741, 1765, 1789, 1813, 1837, 1861, 1885, 1909, 1933, 1957, 1981, 2005, 2029, 2053, 2077, 2101, 2125, 2149, 2173, 2197, 2221, 2245, 2269, 2293, 2317, 2341, 2365, 2389, 2413, 2437, 2461, 2485, 2509, 2533, 3162, 3186, 3210, 3234, 3258, 3282, 3306, 3330, 3354, 3378, 3402, 3426, 3450, 3474, 3498, 3522, 3546,	1 Byte	I	C - W - -	DPT_Scaling	0% - 100%	[Cx] Absolute Dimming	1-Byte Dimmer Control

3570, 3594, 3618, 3642, 3666, 3690, 3714, 3738, 3762, 3786, 3810, 3834, 3858, 3882, 3906, 3930, 3954, 3978, 4002, 4026, 4050, 4074, 4098, 4122, 4146, 4170, 4194, 4218, 4242, 4266, 4290, 4314, 4338, 4362, 4386, 4410, 4434, 4458, 4482, 4506, 4530, 4554, 4578, 4602, 4626, 4650, 4674, 4698, 4722, 4746, 4770, 4794, 4818, 4842, 4866, 4890, 4914, 4938, 4962, 4986, 5010, 5034, 5058, 5082							
614, 638, 662, 686, 710, 734, 758, 782, 806, 830, 854, 878, 902, 926, 950, 974, 998, 1022, 1046, 1070, 1094, 1118, 1142, 1166, 1190, 1214, 1238, 1262, 1286, 1310, 1334, 1358, 1382, 1406, 1430, 1454, 1478, 1502, 1526, 1550, 1574, 1598, 1622, 1646, 1670, 1694, 1718, 1742, 1766, 1790, 1814, 1838, 1862, 1886, 1910, 1934, 1958, 1982, 2006, 2030, 2054, 2078, 2102, 2126, 2150, 2174, 2198, 2222, 2246, 2270, 2294, 2318, 2342, 2366, 2390, 2414, 2438, 2462, 2486, 2510, 2534, 3163, 3187, 3211, 3235, 3259, 3283, 3307, 3331, 3355, 3379, 3403, 3427, 3451, 3475, 3499, 3523, 3547, 3571, 3595, 3619, 3643, 3667, 3691, 3715, 3739, 3763, 3787, 3811, 3835, 3859, 3883, 3907, 3931, 3955, 3979, 4003, 4027, 4051, 4075, 4099, 4123, 4147, 4171, 4195, 4219, 4243, 4267, 4291, 4315, 4339, 4363, 4387, 4411, 4435, 4459, 4483, 4507, 4531, 4555, 4579, 4603, 4627, 4651, 4675, 4699, 4723, 4747, 4771, 4795, 4819, 4843, 4867, 4891, 4915, 4939, 4963, 4987, 5011, 5035, 5059, 5083	4 Bit	I	C - W - - -	DPT_Control_Dimming	0x0/0x8 (Stop) 0x1...0x7 (Dec.) 0x9...0xF (Inc.)	[Cx] Relative Dimming	4-Bit Dimmer Control
615, 639, 663, 687, 711, 735, 759, 783, 807, 831, 855, 879, 903, 927, 951, 975, 999, 1023, 1047, 1071, 1095, 1119, 1143, 1167, 1191, 1215, 1239, 1263, 1287, 1311, 1335, 1359, 1383, 1407, 1431, 1455, 1479, 1503, 1527, 1551, 1575, 1599, 1623, 1647, 1671, 1695, 1719, 1743, 1767, 1791, 1815, 1839, 1863, 1887, 1911, 1935, 1959, 1983, 2007, 2031, 2055, 2079, 2103, 2127, 2151, 2175, 2199, 2223, 2247, 2271, 2295, 2319, 2343, 2367,	1 Byte	O	C R - T -	DPT_Scaling	0% - 100%	[Cx] Dimming Value (Status)	0 - 100%

2391, 2415, 2439, 2463, 2487, 2511, 2535, 3164, 3188, 3212, 3236, 3260, 3284, 3308, 3332, 3356, 3380, 3404, 3428, 3452, 3476, 3500, 3524, 3548, 3572, 3596, 3620, 3644, 3668, 3692, 3716, 3740, 3764, 3788, 3812, 3836, 3860, 3884, 3908, 3932, 3956, 3980, 4004, 4028, 4052, 4076, 4100, 4124, 4148, 4172, 4196, 4220, 4244, 4268, 4292, 4316, 4340, 4364, 4388, 4412, 4436, 4460, 4484, 4508, 4532, 4556, 4580, 4604, 4628, 4652, 4676, 4700, 4724, 4748, 4772, 4796, 4820, 4844, 4868, 4892, 4916, 4940, 4964, 4988, 5012, 5036, 5060, 5084							
616, 640, 664, 688, 712, 736, 760, 784, 808, 832, 856, 880, 904, 928, 952, 976, 1000, 1024, 1048, 1072, 1096, 1120, 1144, 1168, 1192, 1216, 1240, 1264, 1288, 1312, 1336, 1360, 1384, 1408, 1432, 1456, 1480, 1504, 1528, 1552, 1576, 1600, 1624, 1648, 1672, 1696, 1720, 1744, 1768, 1792, 1816, 1840, 1864, 1888, 1912, 1936, 1960, 1984, 2008, 2032, 2056, 2080, 2104, 2128, 2152, 2176, 2200, 2224, 2248, 2272, 2296, 2320, 2344, 2368, 2392, 2416, 2440, 2464, 2488, 2512, 2536, 3165, 3189, 3213, 3237, 3261, 3285, 3309, 3333, 3357, 3381, 3405, 3429, 3453, 3477, 3501, 3525, 3549, 3573, 3597, 3621, 3645, 3669, 3693, 3717, 3741, 3765, 3789, 3813, 3837, 3861, 3885, 3909, 3933, 3957, 3981, 4005, 4029, 4053, 4077, 4101, 4125, 4149, 4173, 4197, 4221, 4245, 4269, 4293, 4317, 4341, 4365, 4389, 4413, 4437, 4461, 4485, 4509, 4533, 4557, 4581, 4605, 4629, 4653, 4677, 4701, 4725, 4749, 4773, 4797, 4821, 4845, 4869, 4893, 4917, 4941, 4965, 4989, 5013, 5037, 5061, 5085	3 Bytes	I	C - W - -	DPT_Colour_RGB	[0 - 255] * 3	[Cx] RGB Channels Absolute Dimming	3-Byte RGB Channels Dimmer Control
	6 Bytes	I	C - W - -	DPT_Colour_RGBW	[0 -1] *4 - [0 - 255] * 4	[Cx] RGBW Channels Absolute Dimming	6-Byte RGBW Channels Dimmer Control
	2 Bytes	I	C - W - -	DPT_Absolute_Colour_Temperature	0 - 65535	[Cx] Colour Temperature	2-Byte Colour Temperature Dimmer Control
	1 Byte	I	C - W - -	DPT_Scaling	0% - 100%	[Cx] R Channel Absolute Dimming	1-Byte R Channel Dimmer Control
617, 641, 665, 689, 713, 737, 761, 785, 809, 833, 857, 881, 905, 929, 953, 977, 1001, 1025, 1049, 1073, 1097, 1121, 1145, 1169, 1193, 1217, 1241, 1265, 1289, 1313, 1337, 1361, 1385, 1409, 1433, 1457, 1481, 1505,	3 Bytes	O	C R - T -	DPT_Colour_RGB	[0 - 255] * 3	[Cx] RGB Channels Dimming Value (Status)	RGB Channels Dimming Status
	6 Bytes	O	C R - T -	DPT_Colour_RGBW	[0 -1] *4 - [0 - 255] * 4	[Cx] RGBW Channels Dimming Value (Status)	RGBW Channels Dimming Status
	2 Bytes	O	C R - T -	DPT_Absolute_Colour_Temperature	0 - 65535	[Cx] Colour Temperature (Status)	Colour Temperature Dimming Status

1529, 1553, 1577, 1601, 1625, 1649, 1673, 1697, 1721, 1745, 1769, 1793, 1817, 1841, 1865, 1889, 1913, 1937, 1961, 1985, 2009, 2033, 2057, 2081, 2105, 2129, 2153, 2177, 2201, 2225, 2249, 2273, 2297, 2321, 2345, 2369, 2393, 2417, 2441, 2465, 2489, 2513, 2537, 3166, 3190, 3214, 3238, 3262, 3286, 3310, 3334, 3358, 3382, 3406, 3430, 3454, 3478, 3502, 3526, 3550, 3574, 3598, 3622, 3646, 3670, 3694, 3718, 3742, 3766, 3790, 3814, 3838, 3862, 3886, 3910, 3934, 3958, 3982, 4006, 4030, 4054, 4078, 4102, 4126, 4150, 4174, 4198, 4222, 4246, 4270, 4294, 4318, 4342, 4366, 4390, 4414, 4438, 4462, 4486, 4510, 4534, 4558, 4582, 4606, 4630, 4654, 4678, 4702, 4726, 4750, 4774, 4798, 4822, 4846, 4870, 4894, 4918, 4942, 4966, 4990, 5014, 5038, 5062, 5086	1 Byte	O	CR - T -	DPT_Scaling	0% - 100%	[Cx] R Channel Dimming Value (Status)	0 - 100%
618, 642, 666, 690, 714, 738, 762, 786, 810, 834, 858, 882, 906, 930, 954, 978, 1002, 1026, 1050, 1074, 1098, 1122, 1146, 1170, 1194, 1218, 1242, 1266, 1290, 1314, 1338, 1362, 1386, 1410, 1434, 1458, 1482, 1506, 1530, 1554, 1578, 1602, 1626, 1650, 1674, 1698, 1722, 1746, 1770, 1794, 1818, 1842, 1866, 1890, 1914, 1938, 1962, 1986, 2010, 2034, 2058, 2082, 2106, 2130, 2154, 2178, 2202, 2226, 2250, 2274, 2298, 2322, 2346, 2370, 2394, 2418, 2442, 2466, 2490, 2514, 2538, 3167, 3191, 3215, 3239, 3263, 3287, 3311, 3335, 3359, 3383, 3407, 3431, 3455, 3479, 3503, 3527, 3551, 3575, 3599, 3623, 3647, 3671, 3695, 3719, 3743, 3767, 3791, 3815, 3839, 3863, 3887, 3911, 3935, 3959, 3983, 4007, 4031, 4055, 4079, 4103, 4127, 4151, 4175, 4199, 4223, 4247, 4271, 4295, 4319, 4343, 4367, 4391, 4415, 4439, 4463, 4487, 4511, 4535, 4559, 4583, 4607, 4631, 4655, 4679, 4703, 4727, 4751, 4775, 4799, 4823, 4847, 4871, 4895, 4919, 4943, 4967, 4991, 5015, 5039, 5063, 5087	1 Byte	I	C - W - -	DPT_Scaling	0% - 100%	[Cx] G Channel Absolute Dimming	1-Byte G Channel Dimmer Control
619, 643, 667, 691, 715, 739, 763, 787, 811, 835, 859, 883, 907, 931,	1 Byte	O	CR - T -	DPT_Scaling	0% - 100%	[Cx] G Channel Dimming Value (Status)	0 - 100%

955, 979, 1003, 1027, 1051, 1075, 1099, 1123, 1147, 1171, 1195, 1219, 1243, 1267, 1291, 1315, 1339, 1363, 1387, 1411, 1435, 1459, 1483, 1507, 1531, 1555, 1579, 1603, 1627, 1651, 1675, 1699, 1723, 1747, 1771, 1795, 1819, 1843, 1867, 1891, 1915, 1939, 1963, 1987, 2011, 2035, 2059, 2083, 2107, 2131, 2155, 2179, 2203, 2227, 2251, 2275, 2299, 2323, 2347, 2371, 2395, 2419, 2443, 2467, 2491, 2515, 2539, 3168, 3192, 3216, 3240, 3264, 3288, 3312, 3336, 3360, 3384, 3408, 3432, 3456, 3480, 3504, 3528, 3552, 3576, 3600, 3624, 3648, 3672, 3696, 3720, 3744, 3768, 3792, 3816, 3840, 3864, 3888, 3912, 3936, 3960, 3984, 4008, 4032, 4056, 4080, 4104, 4128, 4152, 4176, 4200, 4224, 4248, 4272, 4296, 4320, 4344, 4368, 4392, 4416, 4440, 4464, 4488, 4512, 4536, 4560, 4584, 4608, 4632, 4656, 4680, 4704, 4728, 4752, 4776, 4800, 4824, 4848, 4872, 4896, 4920, 4944, 4968, 4992, 5016, 5040, 5064, 5088							
620, 644, 668, 692, 716, 740, 764, 788, 812, 836, 860, 884, 908, 932, 956, 980, 1004, 1028, 1052, 1076, 1100, 1124, 1148, 1172, 1196, 1220, 1244, 1268, 1292, 1316, 1340, 1364, 1388, 1412, 1436, 1460, 1484, 1508, 1532, 1556, 1580, 1604, 1628, 1652, 1676, 1700, 1724, 1748, 1772, 1796, 1820, 1844, 1868, 1892, 1916, 1940, 1964, 1988, 2012, 2036, 2060, 2084, 2108, 2132, 2156, 2180, 2204, 2228, 2252, 2276, 2300, 2324, 2348, 2372, 2396, 2420, 2444, 2468, 2492, 2516, 2540, 3169, 3193, 3217, 3241, 3265, 3289, 3313, 3337, 3361, 3385, 3409, 3433, 3457, 3481, 3505, 3529, 3553, 3577, 3601, 3625, 3649, 3673, 3697, 3721, 3745, 3769, 3793, 3817, 3841, 3865, 3889, 3913, 3937, 3961, 3985, 4009, 4033, 4057, 4081, 4105, 4129, 4153, 4177, 4201, 4225, 4249, 4273, 4297, 4321, 4345, 4369, 4393, 4417, 4441, 4465, 4489, 4513, 4537, 4561, 4585, 4609, 4633, 4657, 4681, 4705, 4729, 4753, 4777, 4801, 4825, 4849,	1 Byte	I	C - W - -	DPT_Scaling	0% - 100%	[Cx] Colour Temperature Absolute Dimming	1-Byte Dimmer Control (0% = Warm, 100% = Cold)
	1 Byte	I	C - W - -	DPT_Scaling	0% - 100%	[Cx] B Channel Absolute Dimming	1-Byte B Channel Dimmer Control

4873, 4897, 4921, 4945, 4969, 4993, 5017, 5041, 5065, 5089							
621, 645, 669, 693, 717, 741, 765, 789, 813, 837, 861, 885, 909, 933, 957, 981, 1005, 1029, 1053, 1077, 1101, 1125, 1149, 1173, 1197, 1221, 1245, 1269, 1293, 1317, 1341, 1365, 1389, 1413, 1437, 1461, 1485, 1509, 1533, 1557, 1581, 1605, 1629, 1653, 1677, 1701, 1725, 1749, 1773, 1797, 1821, 1845, 1869, 1893, 1917, 1941, 1965, 1989, 2013, 2037, 2061, 2085, 2109, 2133, 2157, 2181, 2205, 2229, 2253, 2277, 2301, 2325, 2349, 2373, 2397, 2421, 2445, 2469, 2493, 2517, 2541, 3170, 3194, 3218, 3242, 3266, 3290, 3314, 3338, 3362, 3386, 3410, 3434, 3458, 3482, 3506, 3530, 3554, 3578, 3602, 3626, 3650, 3674, 3698, 3722, 3746, 3770, 3794, 3818, 3842, 3866, 3890, 3914, 3938, 3962, 3986, 4010, 4034, 4058, 4082, 4106, 4130, 4154, 4178, 4202, 4226, 4250, 4274, 4298, 4322, 4346, 4370, 4394, 4418, 4442, 4466, 4490, 4514, 4538, 4562, 4586, 4610, 4634, 4658, 4682, 4706, 4730, 4754, 4778, 4802, 4826, 4850, 4874, 4898, 4922, 4946, 4970, 4994, 5018, 5042, 5066, 5090	1 Byte	O	C R - T -	DPT_Scaling	0% - 100%	[Cx] B Channel Dimming Value (Status)	0 - 100%
622, 646, 670, 694, 718, 742, 766, 790, 814, 838, 862, 886, 910, 934, 958, 982, 1006, 1030, 1054, 1078, 1102, 1126, 1150, 1174, 1198, 1222, 1246, 1270, 1294, 1318, 1342, 1366, 1390, 1414, 1438, 1462, 1486, 1510, 1534, 1558, 1582, 1606, 1630, 1654, 1678, 1702, 1726, 1750, 1774, 1798, 1822, 1846, 1870, 1894, 1918, 1942, 1966, 1990, 2014, 2038, 2062, 2086, 2110, 2134, 2158, 2182, 2206, 2230, 2254, 2278, 2302, 2326, 2350, 2374, 2398, 2422, 2446, 2470, 2494, 2518, 2542, 3171, 3195, 3219, 3243, 3267, 3291, 3315, 3339, 3363, 3387, 3411, 3435, 3459, 3483, 3507, 3531, 3555, 3579, 3603, 3627, 3651, 3675, 3699, 3723, 3747, 3771, 3795, 3819, 3843, 3867, 3891, 3915, 3939, 3963, 3987, 4011, 4035, 4059, 4083, 4107, 4131, 4155, 4179, 4203, 4227, 4251, 4275,	1 Byte	I	C - W - -	DPT_Scaling	0% - 100%	[Cx] W Channel Absolute Dimming	1-Byte W Channel Dimmer Control
	4 Bit	I	C - W - -	DPT_Control_Dimming	0x0/0x8 (Stop) 0x1...0x7 (Dec.) 0x9...0xF (Inc.)	[Cx] Colour Temperature Relative Dimming	4-Bit Dimmer Control (0% = Warm, 100% = Cold)

4299, 4323, 4347, 4371, 4395, 4419, 4443, 4467, 4491, 4515, 4539, 4563, 4587, 4611, 4635, 4659, 4683, 4707, 4731, 4755, 4779, 4803, 4827, 4851, 4875, 4899, 4923, 4947, 4971, 4995, 5019, 5043, 5067, 5091							
623, 647, 671, 695, 719, 743, 767, 791, 815, 839, 863, 887, 911, 935, 959, 983, 1007, 1031, 1055, 1079, 1103, 1127, 1151, 1175, 1199, 1223, 1247, 1271, 1295, 1319, 1343, 1367, 1391, 1415, 1439, 1463, 1487, 1511, 1535, 1559, 1583, 1607, 1631, 1655, 1679, 1703, 1727, 1751, 1775, 1799, 1823, 1847, 1871, 1895, 1919, 1943, 1967, 1991, 2015, 2039, 2063, 2087, 2111, 2135, 2159, 2183, 2207, 2231, 2255, 2279, 2303, 2327, 2351, 2375, 2399, 2423, 2447, 2471, 2495, 2519, 2543, 3172, 3196, 3220, 3244, 3268, 3292, 3316, 3340, 3364, 3388, 3412, 3436, 3460, 3484, 3508, 3532, 3556, 3580, 3604, 3628, 3652, 3676, 3700, 3724, 3748, 3772, 3796, 3820, 3844, 3868, 3892, 3916, 3940, 3964, 3988, 4012, 4036, 4060, 4084, 4108, 4132, 4156, 4180, 4204, 4228, 4252, 4276, 4300, 4324, 4348, 4372, 4396, 4420, 4444, 4468, 4492, 4516, 4540, 4564, 4588, 4612, 4636, 4660, 4684, 4708, 4732, 4756, 4780, 4804, 4828, 4852, 4876, 4900, 4924, 4948, 4972, 4996, 5020, 5044, 5068, 5092	1 Byte	O	CR - T -	DPT_Scaling	0% - 100%	[Cx] W Channel Dimming Value (Status)	0 - 100%
624, 648, 672, 696, 720, 744, 768, 792, 816, 840, 864, 888, 912, 936, 960, 984, 1008, 1032, 1056, 1080, 1104, 1128, 1152, 1176, 1200, 1224, 1248, 1272, 1296, 1320, 1344, 1368, 1392, 1416, 1440, 1464, 1488, 1512, 1536, 1560, 1584, 1608, 1632, 1656, 1680, 1704, 1728, 1752, 1776, 1800, 1824, 1848, 1872, 1896, 1920, 1944, 1968, 1992, 2016, 2040, 2064, 2088, 2112, 2136, 2160, 2184, 2208, 2232, 2256, 2280, 2304, 2328, 2352, 2376, 2400, 2424, 2448, 2472, 2496, 2520, 2544, 3173, 3197, 3221, 3245, 3269, 3293, 3317, 3341, 3365, 3389, 3413, 3437, 3461, 3485, 3509, 3533, 3557, 3581, 3605, 3629, 3653, 3677, 3701,	1 Bit	I	C - W - -	DPT_Switch	0/1	[Cx] Custom On/Off	0 = Off; 1 = On

3725, 3749, 3773, 3797, 3821, 3845, 3869, 3893, 3917, 3941, 3965, 3989, 4013, 4037, 4061, 4085, 4109, 4133, 4157, 4181, 4205, 4229, 4253, 4277, 4301, 4325, 4349, 4373, 4397, 4421, 4445, 4469, 4493, 4517, 4541, 4565, 4589, 4613, 4637, 4661, 4685, 4709, 4733, 4757, 4781, 4805, 4829, 4853, 4877, 4901, 4925, 4949, 4973, 4997, 5021, 5045, 5069, 5093							
625, 649, 673, 697, 721, 745, 769, 793, 817, 841, 865, 889, 913, 937, 961, 985, 1009, 1033, 1057, 1081, 1105, 1129, 1153, 1177, 1201, 1225, 1249, 1273, 1297, 1321, 1345, 1369, 1393, 1417, 1441, 1465, 1489, 1513, 1537, 1561, 1585, 1609, 1633, 1657, 1681, 1705, 1729, 1753, 1777, 1801, 1825, 1849, 1873, 1897, 1921, 1945, 1969, 1993, 2017, 2041, 2065, 2089, 2113, 2137, 2161, 2185, 2209, 2233, 2257, 2281, 2305, 2329, 2353, 2377, 2401, 2425, 2449, 2473, 2497, 2521, 2545, 3174, 3198, 3222, 3246, 3270, 3294, 3318, 3342, 3366, 3390, 3414, 3438, 3462, 3486, 3510, 3534, 3558, 3582, 3606, 3630, 3654, 3678, 3702, 3726, 3750, 3774, 3798, 3822, 3846, 3870, 3894, 3918, 3942, 3966, 3990, 4014, 4038, 4062, 4086, 4110, 4134, 4158, 4182, 4206, 4230, 4254, 4278, 4302, 4326, 4350, 4374, 4398, 4422, 4446, 4470, 4494, 4518, 4542, 4566, 4590, 4614, 4638, 4662, 4686, 4710, 4734, 4758, 4782, 4806, 4830, 4854, 4878, 4902, 4926, 4950, 4974, 4998, 5022, 5046, 5070, 5094	1 Bit	I	C - W - -	DPT_DayNight	0/1	[Cx] Day/Night Mode	0 = Day Mode; 1 = Night Mode
626, 650, 674, 698, 722, 746, 770, 794, 818, 842, 866, 890, 914, 938, 962, 986, 1010, 1034, 1058, 1082, 1106, 1130, 1154, 1178, 1202, 1226, 1250, 1274, 1298, 1322, 1346, 1370, 1394, 1418, 1442, 1466, 1490, 1514, 1538, 1562, 1586, 1610, 1634, 1658, 1682, 1706, 1730, 1754, 1778, 1802, 1826, 1850, 1874, 1898, 1922, 1946, 1970, 1994, 2018, 2042, 2066, 2090, 2114, 2138, 2162, 2186, 2210, 2234, 2258, 2282, 2306, 2330, 2354, 2378, 2402, 2426, 2450, 2474, 2498, 2522,	1 Bit	I	C - W - -	DPT_DayNight	0/1	[Cx] Day/Night Mode	0 = Night Mode; 1 = Day Mode
626, 650, 674, 698, 722, 746, 770, 794, 818, 842, 866, 890, 914, 938, 962, 986, 1010, 1034, 1058, 1082, 1106, 1130, 1154, 1178, 1202, 1226, 1250, 1274, 1298, 1322, 1346, 1370, 1394, 1418, 1442, 1466, 1490, 1514, 1538, 1562, 1586, 1610, 1634, 1658, 1682, 1706, 1730, 1754, 1778, 1802, 1826, 1850, 1874, 1898, 1922, 1946, 1970, 1994, 2018, 2042, 2066, 2090, 2114, 2138, 2162, 2186, 2210, 2234, 2258, 2282, 2306, 2330, 2354, 2378, 2402, 2426, 2450, 2474, 2498, 2522,	1 Bit	I	C - W - -	DPT_Switch	0/1	[Cx] Day/Night Mode On/Off	0 = Off; 1 = On

2546, 3175, 3199, 3223, 3247, 3271, 3295, 3319, 3343, 3367, 3391, 3415, 3439, 3463, 3487, 3511, 3535, 3559, 3583, 3607, 3631, 3655, 3679, 3703, 3727, 3751, 3775, 3799, 3823, 3847, 3871, 3895, 3919, 3943, 3967, 3991, 4015, 4039, 4063, 4087, 4111, 4135, 4159, 4183, 4207, 4231, 4255, 4279, 4303, 4327, 4351, 4375, 4399, 4423, 4447, 4471, 4495, 4519, 4543, 4567, 4591, 4615, 4639, 4663, 4687, 4711, 4735, 4759, 4783, 4807, 4831, 4855, 4879, 4903, 4927, 4951, 4975, 4999, 5023, 5047, 5071, 5095							
627, 651, 675, 699, 723, 747, 771, 795, 819, 843, 867, 891, 915, 939, 963, 987, 1011, 1035, 1059, 1083, 1107, 1131, 1155, 1179, 1203, 1227, 1251, 1275, 1299, 1323, 1347, 1371, 1395, 1419, 1443, 1467, 1491, 1515, 1539, 1563, 1587, 1611, 1635, 1659, 1683, 1707, 1731, 1755, 1779, 1803, 1827, 1851, 1875, 1899, 1923, 1947, 1971, 1995, 2019, 2043, 2067, 2091, 2115, 2139, 2163, 2187, 2211, 2235, 2259, 2283, 2307, 2331, 2355, 2379, 2403, 2427, 2451, 2475, 2499, 2523, 2547, 3176, 3200, 3224, 3248, 3272, 3296, 3320, 3344, 3368, 3392, 3416, 3440, 3464, 3488, 3512, 3536, 3560, 3584, 3608, 3632, 3656, 3680, 3704, 3728, 3752, 3776, 3800, 3824, 3848, 3872, 3896, 3920, 3944, 3968, 3992, 4016, 4040, 4064, 4088, 4112, 4136, 4160, 4184, 4208, 4232, 4256, 4280, 4304, 4328, 4352, 4376, 4400, 4424, 4448, 4472, 4496, 4520, 4544, 4568, 4592, 4616, 4640, 4664, 4688, 4712, 4736, 4760, 4784, 4808, 4832, 4856, 4880, 4904, 4928, 4952, 4976, 5000, 5024, 5048, 5072, 5096	1 Bit	I	C - W - -	DPT_Start	0/1	[Cx] Simple Timer	0 = Deactivate; 1 = Activate
628, 652, 676, 700, 724, 748, 772, 796, 820, 844, 868, 892, 916, 940, 964, 988, 1012, 1036, 1060, 1084, 1108, 1132, 1156, 1180, 1204, 1228, 1252, 1276, 1300, 1324, 1348, 1372, 1396, 1420, 1444, 1468, 1492, 1516, 1540, 1564, 1588, 1612, 1636, 1660, 1684, 1708, 1732, 1756, 1780, 1804, 1828, 1852, 1876, 1900, 1924, 1948,	1 Bit	I	C - W - -	DPT_Start	0/1	[Cx] Flashing	0 = Deactivate; 1 = Activate

1972, 1996, 2020, 2044, 2068, 2092, 2116, 2140, 2164, 2188, 2212, 2236, 2260, 2284, 2308, 2332, 2356, 2380, 2404, 2428, 2452, 2476, 2500, 2524, 2548, 3177, 3201, 3225, 3249, 3273, 3297, 3321, 3345, 3369, 3393, 3417, 3441, 3465, 3489, 3513, 3537, 3561, 3585, 3609, 3633, 3657, 3681, 3705, 3729, 3753, 3777, 3801, 3825, 3849, 3873, 3897, 3921, 3945, 3969, 3993, 4017, 4041, 4065, 4089, 4113, 4137, 4161, 4185, 4209, 4233, 4257, 4281, 4305, 4329, 4353, 4377, 4401, 4425, 4449, 4473, 4497, 4521, 4545, 4569, 4593, 4617, 4641, 4665, 4689, 4713, 4737, 4761, 4785, 4809, 4833, 4857, 4881, 4905, 4929, 4953, 4977, 5001, 5025, 5049, 5073, 5097							
629, 653, 677, 701, 725, 749, 773, 797, 821, 845, 869, 893, 917, 941, 965, 989, 1013, 1037, 1061, 1085, 1109, 1133, 1157, 1181, 1205, 1229, 1253, 1277, 1301, 1325, 1349, 1373, 1397, 1421, 1445, 1469, 1493, 1517, 1541, 1565, 1589, 1613, 1637, 1661, 1685, 1709, 1733, 1757, 1781, 1805, 1829, 1853, 1877, 1901, 1925, 1949, 1973, 1997, 2021, 2045, 2069, 2093, 2117, 2141, 2165, 2189, 2213, 2237, 2261, 2285, 2309, 2333, 2357, 2381, 2405, 2429, 2453, 2477, 2501, 2525, 2549, 3178, 3202, 3226, 3250, 3274, 3298, 3322, 3346, 3370, 3394, 3418, 3442, 3466, 3490, 3514, 3538, 3562, 3586, 3610, 3634, 3658, 3682, 3706, 3730, 3754, 3778, 3802, 3826, 3850, 3874, 3898, 3922, 3946, 3970, 3994, 4018, 4042, 4066, 4090, 4114, 4138, 4162, 4186, 4210, 4234, 4258, 4282, 4306, 4330, 4354, 4378, 4402, 4426, 4450, 4474, 4498, 4522, 4546, 4570, 4594, 4618, 4642, 4666, 4690, 4714, 4738, 4762, 4786, 4810, 4834, 4858, 4882, 4906, 4930, 4954, 4978, 5002, 5026, 5050, 5074, 5098	1 Bit	I	C - W - -	DPT_Enable	0/1	[Cx] Lock	0 = Unlock; 1 = Lock
630, 654, 678, 702, 726, 750, 774, 798, 822, 846, 870, 894, 918, 942, 966, 990, 1014, 1038, 1062, 1086, 1110, 1134, 1158, 1182, 1206, 1230, 1254, 1278, 1302, 1326, 1350, 1374,	1 Bit	I	C - W - -	DPT_Alarm	0/1	[Cx] Alarm	0 = No Alarm; 1 = Alarm
630, 654, 678, 702, 726, 750, 774, 798, 822, 846, 870, 894, 918, 942, 966, 990, 1014, 1038, 1062, 1086, 1110, 1134, 1158, 1182, 1206, 1230, 1254, 1278, 1302, 1326, 1350, 1374,	1 Bit	I	C - W - -	DPT_Alarm	0/1	[Cx] Alarm	0 = Alarm; 1 = No Alarm

<p>1398, 1422, 1446, 1470, 1494, 1518, 1542, 1566, 1590, 1614, 1638, 1662, 1686, 1710, 1734, 1758, 1782, 1806, 1830, 1854, 1878, 1902, 1926, 1950, 1974, 1998, 2022, 2046, 2070, 2094, 2118, 2142, 2166, 2190, 2214, 2238, 2262, 2286, 2310, 2334, 2358, 2382, 2406, 2430, 2454, 2478, 2502, 2526, 2550, 3179, 3203, 3227, 3251, 3275, 3299, 3323, 3347, 3371, 3395, 3419, 3443, 3467, 3491, 3515, 3539, 3563, 3587, 3611, 3635, 3659, 3683, 3707, 3731, 3755, 3779, 3803, 3827, 3851, 3875, 3899, 3923, 3947, 3971, 3995, 4019, 4043, 4067, 4091, 4115, 4139, 4163, 4187, 4211, 4235, 4259, 4283, 4307, 4331, 4355, 4379, 4403, 4427, 4451, 4475, 4499, 4523, 4547, 4571, 4595, 4619, 4643, 4667, 4691, 4715, 4739, 4763, 4787, 4811, 4835, 4859, 4883, 4907, 4931, 4955, 4979, 5003, 5027, 5051, 5075, 5099</p>							
<p>631, 655, 679, 703, 727, 751, 775, 799, 823, 847, 871, 895, 919, 943, 967, 991, 1015, 1039, 1063, 1087, 1111, 1135, 1159, 1183, 1207, 1231, 1255, 1279, 1303, 1327, 1351, 1375, 1399, 1423, 1447, 1471, 1495, 1519, 1543, 1567, 1591, 1615, 1639, 1663, 1687, 1711, 1735, 1759, 1783, 1807, 1831, 1855, 1879, 1903, 1927, 1951, 1975, 1999, 2023, 2047, 2071, 2095, 2119, 2143, 2167, 2191, 2215, 2239, 2263, 2287, 2311, 2335, 2359, 2383, 2407, 2431, 2455, 2479, 2503, 2527, 2551, 3180, 3204, 3228, 3252, 3276, 3300, 3324, 3348, 3372, 3396, 3420, 3444, 3468, 3492, 3516, 3540, 3564, 3588, 3612, 3636, 3660, 3684, 3708, 3732, 3756, 3780, 3804, 3828, 3852, 3876, 3900, 3924, 3948, 3972, 3996, 4020, 4044, 4068, 4092, 4116, 4140, 4164, 4188, 4212, 4236, 4260, 4284, 4308, 4332, 4356, 4380, 4404, 4428, 4452, 4476, 4500, 4524, 4548, 4572, 4596, 4620, 4644, 4668, 4692, 4716, 4740, 4764, 4788, 4812, 4836, 4860, 4884, 4908, 4932, 4956, 4980, 5004, 5028, 5052, 5076, 5100</p>	1 Bit	I	C - W - -	DPT_Ack	0/1	[Cx] Unfreeze Alarm	No Alarm + Unfreeze (1) => End Alarm

632, 656, 680, 704, 728, 752, 776, 800, 824, 848, 872, 896, 920, 944, 968, 992, 1016, 1040, 1064, 1088, 1112, 1136, 1160, 1184, 1208, 1232, 1256, 1280, 1304, 1328, 1352, 1376, 1400, 1424, 1448, 1472, 1496, 1520, 1544, 1568, 1592, 1616, 1640, 1664, 1688, 1712, 1736, 1760, 1784, 1808, 1832, 1856, 1880, 1904, 1928, 1952, 1976, 2000, 2024, 2048, 2072, 2096, 2120, 2144, 2168, 2192, 2216, 2240, 2264, 2288, 2312, 2336, 2360, 2384, 2408, 2432, 2456, 2480, 2504, 2528, 2552, 3181, 3205, 3229, 3253, 3277, 3301, 3325, 3349, 3373, 3397, 3421, 3445, 3469, 3493, 3517, 3541, 3565, 3589, 3613, 3637, 3661, 3685, 3709, 3733, 3757, 3781, 3805, 3829, 3853, 3877, 3901, 3925, 3949, 3973, 3997, 4021, 4045, 4069, 4093, 4117, 4141, 4165, 4189, 4213, 4237, 4261, 4285, 4309, 4333, 4357, 4381, 4405, 4429, 4453, 4477, 4501, 4525, 4549, 4573, 4597, 4621, 4645, 4669, 4693, 4717, 4741, 4765, 4789, 4813, 4837, 4861, 4885, 4909, 4933, 4957, 4981, 5005, 5029, 5053, 5077, 5101	1 Bit	I	C - W - -	DPT_Enable	0/1	[Cx] Burn-in Mode	0 = Stop Burn-in; 1 = Start Burn-in
633, 657, 681, 705, 729, 753, 777, 801, 825, 849, 873, 897, 921, 945, 969, 993, 1017, 1041, 1065, 1089, 1113, 1137, 1161, 1185, 1209, 1233, 1257, 1281, 1305, 1329, 1353, 1377, 1401, 1425, 1449, 1473, 1497, 1521, 1545, 1569, 1593, 1617, 1641, 1665, 1689, 1713, 1737, 1761, 1785, 1809, 1833, 1857, 1881, 1905, 1929, 1953, 1977, 2001, 2025, 2049, 2073, 2097, 2121, 2145, 2169, 2193, 2217, 2241, 2265, 2289, 2313, 2337, 2361, 2385, 2409, 2433, 2457, 2481, 2505, 2529, 2553, 3182, 3206, 3230, 3254, 3278, 3302, 3326, 3350, 3374, 3398, 3422, 3446, 3470, 3494, 3518, 3542, 3566, 3590, 3614, 3638, 3662, 3686, 3710, 3734, 3758, 3782, 3806, 3830, 3854, 3878, 3902, 3926, 3950, 3974, 3998, 4022, 4046, 4070, 4094, 4118, 4142, 4166, 4190, 4214, 4238, 4262, 4286, 4310, 4334, 4358, 4382, 4406, 4430, 4454, 4478, 4502, 4526, 4550, 4574,	1 Bit	O	C R - T -	DPT_Enable	0/1	[Cx] Burn-in Mode (Status)	0 = Burn-in Inactive; 1 = Burn-in Active

4598, 4622, 4646, 4670, 4694, 4718, 4742, 4766, 4790, 4814, 4838, 4862, 4886, 4910, 4934, 4958, 4982, 5006, 5030, 5054, 5078, 5102							
634, 658, 682, 706, 730, 754, 778, 802, 826, 850, 874, 898, 922, 946, 970, 994, 1018, 1042, 1066, 1090, 1114, 1138, 1162, 1186, 1210, 1234, 1258, 1282, 1306, 1330, 1354, 1378, 1402, 1426, 1450, 1474, 1498, 1522, 1546, 1570, 1594, 1618, 1642, 1666, 1690, 1714, 1738, 1762, 1786, 1810, 1834, 1858, 1882, 1906, 1930, 1954, 1978, 2002, 2026, 2050, 2074, 2098, 2122, 2146, 2170, 2194, 2218, 2242, 2266, 2290, 2314, 2338, 2362, 2386, 2410, 2434, 2458, 2482, 2506, 2530, 2554, 3183, 3207, 3231, 3255, 3279, 3303, 3327, 3351, 3375, 3399, 3423, 3447, 3471, 3495, 3519, 3543, 3567, 3591, 3615, 3639, 3663, 3687, 3711, 3735, 3759, 3783, 3807, 3831, 3855, 3879, 3903, 3927, 3951, 3975, 3999, 4023, 4047, 4071, 4095, 4119, 4143, 4167, 4191, 4215, 4239, 4263, 4287, 4311, 4335, 4359, 4383, 4407, 4431, 4455, 4479, 4503, 4527, 4551, 4575, 4599, 4623, 4647, 4671, 4695, 4719, 4743, 4767, 4791, 4815, 4839, 4863, 4887, 4911, 4935, 4959, 4983, 5007, 5031, 5055, 5079, 5103	4 Bytes	I/O	CRW--	DPT_LongDeltaTimeSec	-2147483648 - 2147483647	[Cx] Burn-in Mode Time	[0 ... 918000] s (0 = Disabled)



Join and send us your inquiries
about Zennio devices:

<https://support.zennio.com>

Zennio Avance y Tecnología S.L.

C/ Río Jarama, 132. Nave P-8.11
45007 Toledo, Spain.

Tel. +34 925 232 002.

www.zennio.com

info@zennio.com